

HMP230 Series Transmitters

USER'S GUIDE

M210225en-B
May 2002

PUBLISHED BY

Vaisala Oyj Phone : (+358 9) 894 91
P.O. Box 26 Fax: (+358 9) 8949 2227
FIN-00421 Helsinki
Finland

Visit our Internet pages at <http://www.vaisala.com/>

© Vaisala 2002

No part of this manual may be reproduced in any form or by any means, electronic or mechanical (including photocopying), nor may its contents be communicated to a third party without prior written permission of the copyright holder.

The contents are subject to change without prior notice.

Contents

1. PRODUCT DESCRIPTION	1
2. TO BE NOTED WHEN MEASURING HUMIDITY	3
3. INSTALLATION	4
3.1. Selecting the place of installation	4
3.2. Mounting	5
3.2.1. Mounting the HMP231	5
3.2.2. Installing the HMP233, HMP234 and HMP235	5
3.2.3. HMP233 transmitter	6
3.2.4. HMP234 transmitter	7
3.2.5. HMP235 transmitter	10
3.2.6. HMP237 transmitter	11
3.2.7. HMP238 transmitter	12
3.2.7.1. Mounting; overview	13
3.2.7.2. Installing the probe through the ball valve assembly	16
3.3. Grounding	20
3.4. Electrical connections	22
3.4.1. Connection to a 24 VAC supply	23
4. COMMISSIONING	24
4.1. Changing the parameters	24
4.2. Security lock jumper	24
4.3. Selecting the analogue outputs	25
4.4. Connecting the RS 232C serial bus	27
4.4.1. Reverting to factory settings of the serial port	29
5. CONNECTION TO PC	31
5.1. Giving the communication parameters	31
6. COMMANDS	34
6.1. Commands and security lock jumper	34
6.2. LED commands	35
6.3. Display/keypad commands	36
6.3.1. Display mode	36
6.3.2. Command mode	36
6.3.3. Entering numbers	36
6.3.4. Analogue output commands	37
6.3.4.1. Selecting the output (mA/V)	37
6.3.4.2. Selecting and scaling the analogue output quantities	38
6.3.5. Output via the serial bus	39
6.3.5.1. Turning the serial interface echo ON/OFF	39
6.3.5.2. Serial bus settings	39
6.3.5.3. Setting the transmitter address	40
6.3.5.4. Selecting the output units	41
6.3.5.5. Selecting the calculation mode	41
6.3.6. Output modes	41
6.3.6.1. Setting the serial interface operation mode	42
6.3.7. Others	43
6.3.7.1. Setting the averaging time	43

6.3.7.2.	Setting the pressure for pressure compenstion of the HUMICAP sensor and for mixing ratio, wet bulb and enthalpy calculations	43
6.3.7.3.	Setting the date	44
6.3.7.4.	Setting the time	44
6.4.	Serial commands	46
6.4.1.	Analogue output commands	46
6.4.1.1.	Setting the analogue outputs	46
6.4.1.2.	Selecting and scaling the analogue output quantities	47
6.4.1.3.	Scaling the analogue outputs	47
6.4.2.	Output via the serial bus	48
6.4.2.1.	Starting the measurement output	48
6.4.2.2.	Stopping the measurement output	48
6.4.2.3.	Outputting the reading once	48
6.4.2.4.	Setting the output interval for the RUN mode	49
6.4.2.5.	Serial bus settings	49
6.4.2.6.	Selecting the output units	50
6.4.2.7.	Setting the averaging time	50
6.4.2.8.	Setting the transmitter address	50
6.4.2.9.	Setting the calculation mode	51
6.4.2.10.	Resetting the transmitter	51
6.4.3.	Operating the transmitter via the serial bus	51
6.4.3.1.	Setting the serial interface	51
6.4.3.2.	OPEN & CLOSE	52
7.	CALIBRATION	53
7.1.	Humidity calibration	53
7.1.1.	One point calibration procedure	54
7.1.1.1.	With serial commands	54
7.1.1.2.	With display/keypad commands	55
7.1.1.3.	With LED commands	55
7.1.2.	Two point calibration procedure	55
7.1.2.1.	With serial commands	56
7.1.2.2.	With display/keypad commands	56
7.1.2.3.	With LED commands	57
7.1.3.	Calibration procedure after sensor change	57
7.1.3.1.	With serial commands	57
7.1.3.2.	With display/keypad commands	58
7.1.3.3.	With LED commands	58
7.1.4.	Humidity calibration table	59
7.2.	Temperature calibration	60
7.2.1.	One point offset correction	60
7.2.1.1.	With serial commands	60
7.2.1.2.	With display/keypad commands	61
7.2.1.3.	With LED commands	61
7.2.2.	Two point temperature calibration	62
7.2.2.1.	With serial commands	62
7.2.2.2.	With display/keypad commands	62
7.2.2.3.	With LED commands	63
7.3.	Calibration of the analogue outputs	63
7.3.1.	With serial commands	63
7.3.2.	With display/keypad commands	64
7.3.3.	With LED commands	64
8.	MAINTENANCE	66
8.1.	Reference measurements	66
8.2.	Self-diagnostics	66
8.3.	Changing the HUMICAP® sensor and the filter	67

8.4.	Temperature channel adjustment with Pt 100 simulators	67
8.4.1.	Adjustment using serial commands.....	67
8.4.2.	Adjustment using display commands.....	68
8.4.3.	Adjustment using LED commands.....	68
8.5.	Measurement of output currents using test points	69
8.6.	Adjusting the contrast of the display	70
9.	TECHNICAL DATA	71
9.1.	Relative humidity	71
9.2.	Temperature	71
9.3.	Calculated variables	71
9.4.	Pressure	73
9.5.	Analogue outputs.....	73
9.6.	Electronics	74
9.7.	Mechanics	75
9.8.	Electromagnetic compatibility.....	77
10.	SPARE PARTS AND OPTIONS	78
11.	FACTORY CALIBRATION AND REPAIR SERVICE	79
Appendix 1	Serial commands	80
Appendix 2	Installing the power supply module	103
Appendix 3	Installing and using the RS 485/422 serial port module	106
Appendix 4	Installing and using the digital current loop module	117
Appendix 5	Error messages	127
Appendix 6	Calculation formulas	133
Appendix 7	Alarm output unit	135
Appendix 8	Connectors	140
Appendix 9	Re-gaining	144
Appendix 10	Pressure conversion chart	155
Appendix 11	Wiring diagramme MK4456	156
Warranty	157

This page intentionally left blank.

1. PRODUCT DESCRIPTION

The HMP230 series transmitters are microprocessor based instruments for the measurement of relative humidity and temperature; from these variables they can calculate dewpoint temperature, absolute humidity, mixing ratio, wet bulb temperature and enthalpy. The transmitters have two analogue outputs and they can be connected to a serial bus via the RS 232C interface or through an RS 485/422 serial module or a current loop module. At dewpoint temperatures below 0 °C, the user can select whether the transmitter calculates dewpoint or frostpoint reading; as default, the transmitter calculates dewpoint.

The series consists of four types of transmitters:

HMP231, wall installation

HMP233, ifor tight places; temperatures up to +80 or +120 °C

HMP234, forpressure or vacuum chambers

HMP235, for high temperatures of +180 °C

HMP237, leak proof small size probe for pressures up to 10 bar

HMP238, for pressurized processes

The transmitters can be configured in many ways. They can have either a blank cover or a cover with a local display and keypad with which the user can operate the transmitter. The power supply voltage can be selected from three alternatives. Two analogue output signals are selected from the measured and calculated quantities; the signals can be scaled and the measurement ranges changed within certain limits. The HMP233, HMP234, HMP235, HMP237 and HMP238 probes can be supplied with two, five or ten metre sensor head cable.

The humidity measuring range is 0...100 %RH. The temperature is measured with a Pt 100 sensor. Temperature measurement range depends on the model; the HMP234, HMP235, HMP237 and HMP238 have the widest range, -40...+180 °C. The analogue temperature output can be scaled quite freely, for example -20...+60 °C can be set to correspond to 0...10 V. The dewpoint temperature, absolute humidity, mixing ratio, wet bulb temperature and enthalpy ranges are also scalable.

In some applications the sensor gain may gradually decrease because of an interference caused by some chemical present in the ambient. These changes can be recovered with an optional re-gaining function. Transmitters including this function are equipped with a composite humidity and temperature sensor.

The HMP230 series units incorporate the HUMICAP® sensor, which uses an operating principle based on changes in the capacitance of the sensor as its thin polymer film absorbs water molecules.

Options	
Calculation variables	dewpoint temperature, mixing ratio, absolute humidity, wet bulb temperature, enthalpy
Power supply	24 VDC (standard), (for 24 VAC, see page 23) 115/230 VAC
Serial interface	RS 232C (standard), RS 485/422, current loop
Display cover	cover with or without local display & keypad
Filters	sintered filter, PPS grid with steel netting, PPS grid
Cable length	2, 5 or 10 metres
Alarm output unit	Not with 115/230 VAC power supply and not with HMP231
Cable connectors	For 24 VDC supply, for analogue outputs, for RS 232C line and for RS 485 single loop line; see Appendix 8 for details
Installation aids	HMP233: installation kits for +80 °C and +120 °C cables HMP234: NPT conical pipe threaded fitting body (1/2 - 14 NPT) HMP235: steel and aluminium flanges HMP237, installation kit for duct mounting HMP238: ball valve set

2. TO BE NOTED WHEN MEASURING HUMIDITY

In the measurement of humidity and especially in calibration it is essential that temperature equilibrium is reached. Even a small difference in temperature between the measured object and the sensor causes an error. If the temperature is +20 °C (+68 °F) and the relative humidity 50 %RH, a difference of ± 1 °C between the measured object and the sensor causes an error of ± 3 %RH. When the humidity is 90 %RH, the corresponding error is ± 5.4 %RH.

The error is at its greatest when the sensor is colder or warmer than the surroundings and the humidity is high. A temperature difference of a few degrees can cause water to condense on the sensor surface. In an unventilated space evaporation may take hours; good ventilation accelerates evaporation. The HUMICAP sensor starts to function normally as soon as the water has evaporated. If the condensed water is contaminated, the life span of the sensor may shorten and calibration may change.

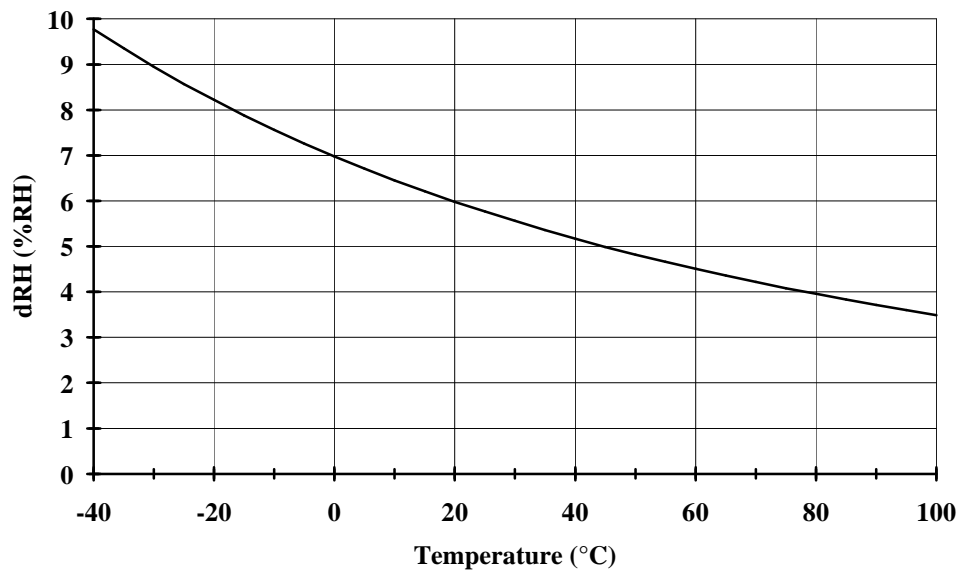

Figure 1 Measurement error at 100 %RH when the difference between the ambient and sensor temperature is 1 °C

3. INSTALLATION

3.1. Selecting the place of installation

Choose a place which gives a true picture of the environment or process, and is as clean as possible. Air should circulate freely around the sensor. A rapid air flow is recommended; it ensures that the sensor head and the ambient air are at the same temperature.

Install the transmitter in a place where no cold or hot spot can develop. When the sensor head is installed in a duct or process channel where the temperature is different from the ambient temperature, insulate the point of entry; this is particularly important if the transmitter is installed with the sensor head pointing downwards. Installing the sensor head of the HMP233, HMP234 and HMP235 vertically is not recommended. An uninsulated installation could lead to condensation in the sensor head and even when no condensation occurs, the resultant air flow may change the temperature near the sensor and distort the readings.

Install the sensor head in the process wherever possible; avoid sample flows where the gas temperature can drop below dewpoint temperature. Install the sensor head transversely against the direction of the process flow.

In duct or channel installations drill a hole ready for a reference meter. Plug the reference hole tightly.

Install the electronics housing away from possible steams escaping from the process.

NOTE

To ensure an IP 65 class protection:

1. Always mount the transmitter housing with the cable bushings pointing downwards.
2. Make sure that the connection cable has the right thickness (7...10 mm) and that the cable bushing is carefully tightened.
3. Pay always special attention to closing the transmitter cover carefully and remember to tighten all four screws.

3.2. Mounting

3.2.1. Mounting the HMP231

The best position for mounting the HMP231 is with the probe head pointing downwards. Due to internal heat transfer, the transmitter should not be mounted with the probe pointing upwards.

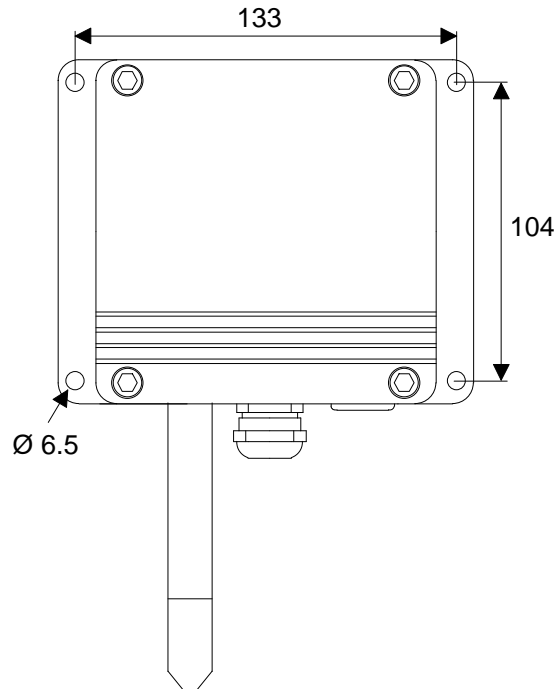

Figure 2 Mounting holes in the HMP230 transmitter housing.

3.2.2. Installing the HMP233, HMP234 and HMP235

It is recommended that the cable models HMP233, HMP234 and HMP235 be mounted with the sensor head horizontally; this way, any water condensing on the tube cannot flow onto the sensors. When there is no alternative but to install the sensor head in the process vertically, the point of entry must be carefully insulated. The cable must also be allowed to hang loosely as in Figure 6; this prevents any condensed water from running onto the sensor head along the cable.

If the process temperature is much higher than that of the environment, the whole sensor head and preferably a piece of the cable must be inside the process.

When mounted on the side of a duct or channel, the sensor head must be inserted from the side (see Figure 8). If this is not possible and the sensor head must be inserted from the top, the point of entry must be carefully insulated.

NOTE

During installation the sensor head must not be unsoldered from and again resoldered to the main printed board of the transmitter. This procedure may damage the humidity calibration of the transmitter.

3.2.3. HMP233 transmitter

The HMP233 can be installed in ducts and channels with the help of the installation kit available; the kit consists of a flange, a supporting bar for the sensor head cable and screws for attaching the flange to the wall of a duct. With the help of the installation kit the distance between the sensor head and the channel wall can be easily adjusted. The range of adjustment is 100...320 mm; the distance is measured from the tip of the sensor head to the flange.

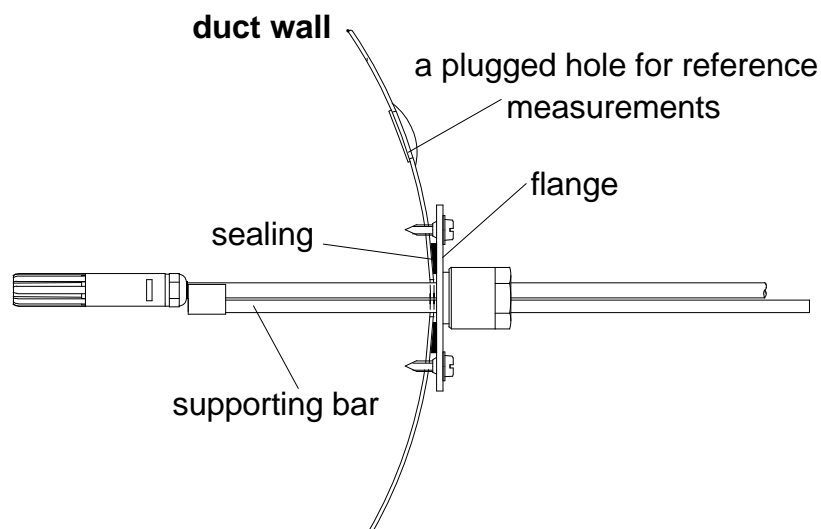
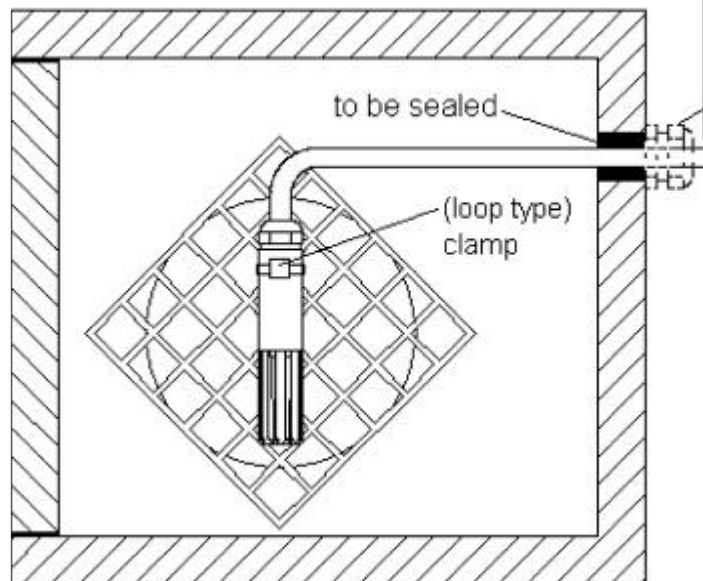

Figure 3 Installing the sensor head of the HMP233 in a channel with the help of flange and supporting bar.

The sensor head can also be installed vertically.



When a bushing is used, its size is selected according to the diameter of the sensor head; the diameter of the cable is increased by using e.g. tape at the bushing

Figure 4 Vertical installation of the HMP233 sensor head

3.2.4. HMP234 transmitter

The atmospheric pressure has an effect on mixing ratio, wet bulb temperature and enthalpy. Therefore, accurate calculations can be achieved only when the ambient pressure is taken into consideration. The pressure is used for pressure compensation of the HUMICAP sensor in order to ensure the best possible measurement accuracy. **If the process pressure differs from normal ambient pressure, the value has to be entered in the transmitter memory when using the transmitters HMP234 or HMP238.** The pressure to be entered is the absolute pressure in hPa or mbar (for pressure unit conversion, see Appendix 10).

The HMP234 is supplied with a nut, a fitting body and a sealing washer. During handling the fitting body and the nut should remain in place on the body of the sensor head to prevent damage to the highly polished surface.

To achieve a leak-tight assembly:

1. Remove the fitting body from the nut and the sensor head.
2. Fasten the fitting body to the chamber wall. Tighten the fitting body into the threaded sleeve with a torque spanner. The tightening torque is 150 ± 10 Nm.
3. Insert the body of the sensor head into the fitting body and screw the nut manually to the fitting body until the connection feels tight.

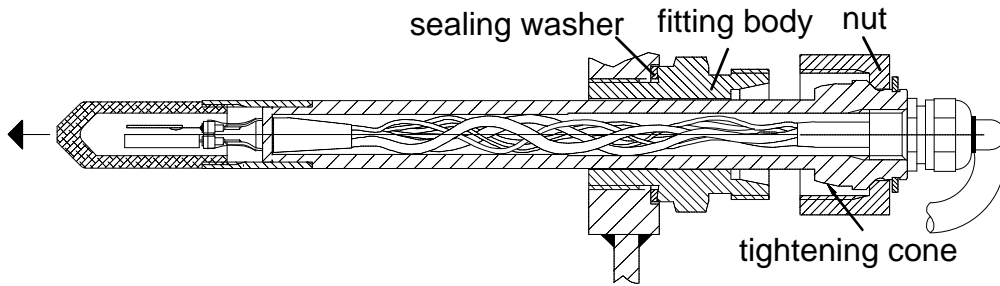

4. Mark both the fitting body and the nut hex.

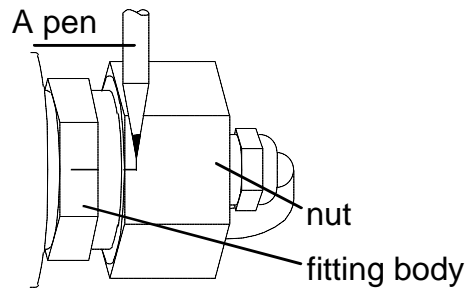

5. Tighten the nut a further 30° (1/12 turn) or if you have a torque spanner tighten it with a torque of 80 ± 10 Nm. NOTE: after detachment the nut must be tightened without increased effort.

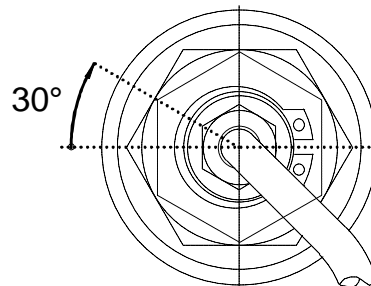

6. The tightening cone of the fitting body has to be cleaned and greased after every tenth detachment. Use high-vacuum grease (Down Corning, Europe) or a similar grease.

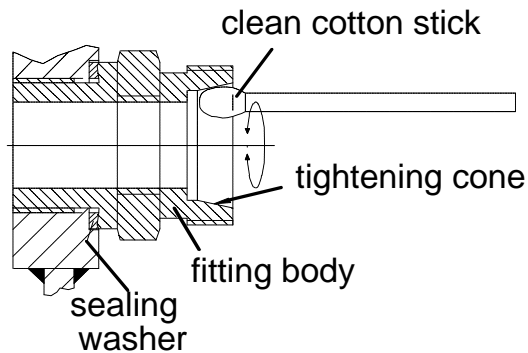

The sealing washer has to be changed every time the fitting body is detached.

Fasten by threaded sleeve

Sealing by Metal sealing washer DIN 7603

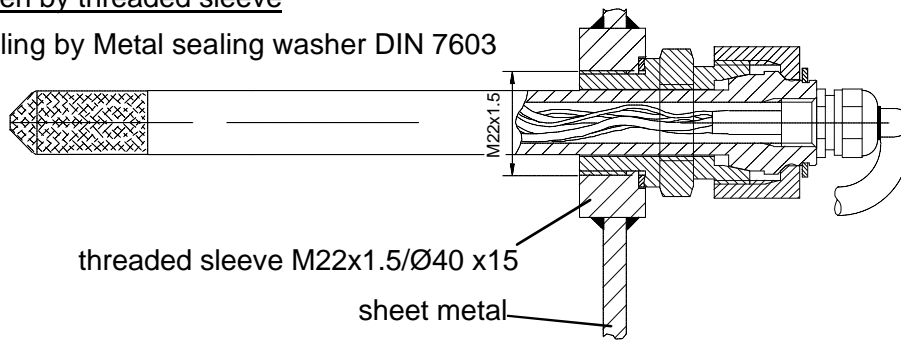

threaded sleeve M22x1.5/Ø40 x15

sheet metal

Fasten by Nut DIN 80705

Check the thickness of the sheet metal according to the pressure of the chamber

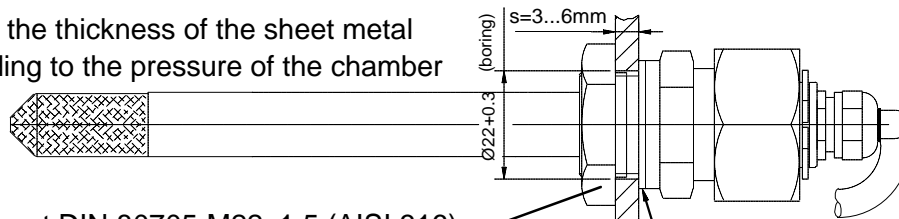
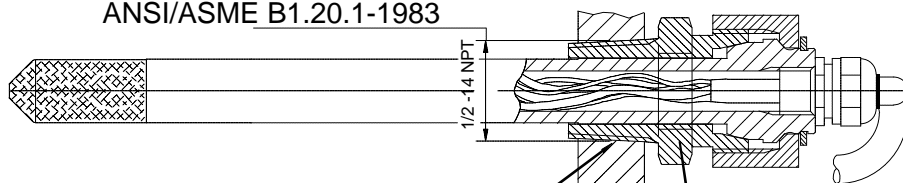
nut DIN 80705-M22x1.5 (AISI 316)
tightening torque=150 Nm ±10 Nmsealing by Metal sealing washer
DIN 7603NPT Conical pipe threaded connection
ANSI/ASME B1.20.1-1983sealing by anaerobic pipe thread seal
(SWAK, Cajon Company) or PTFE
(teflon) tapefitting body. VAISALA code 17225
(AISI 316Ti). Body hex = 27 mm
tightening torque=150 Nm ±10 Nm**Figure 5** Some examples on the installation of the HMP234 sensor head

3.2.5. HMP235 transmitter

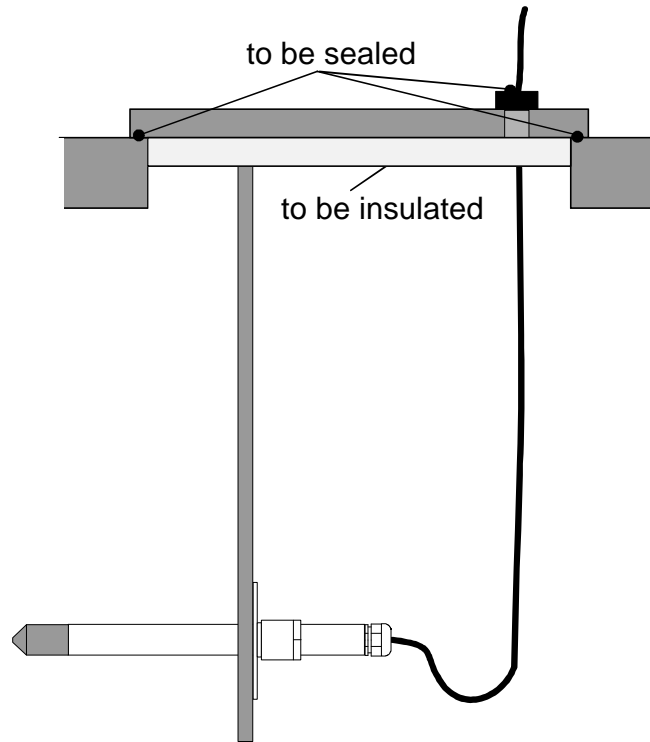

Figure 6 Installing a transmitter in a process with the sensor head horizontally

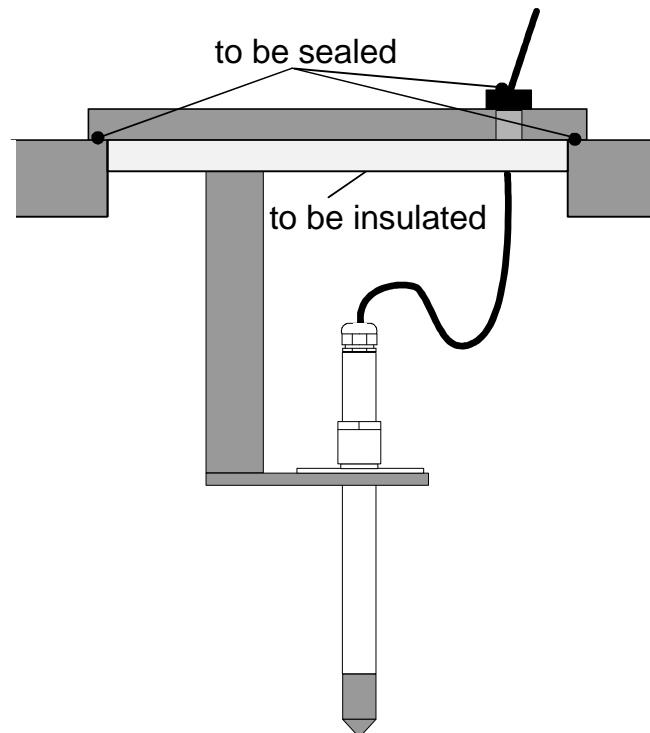

Figure 7 Installing a transmitter in a process with the sensor head downwards (not recommended)

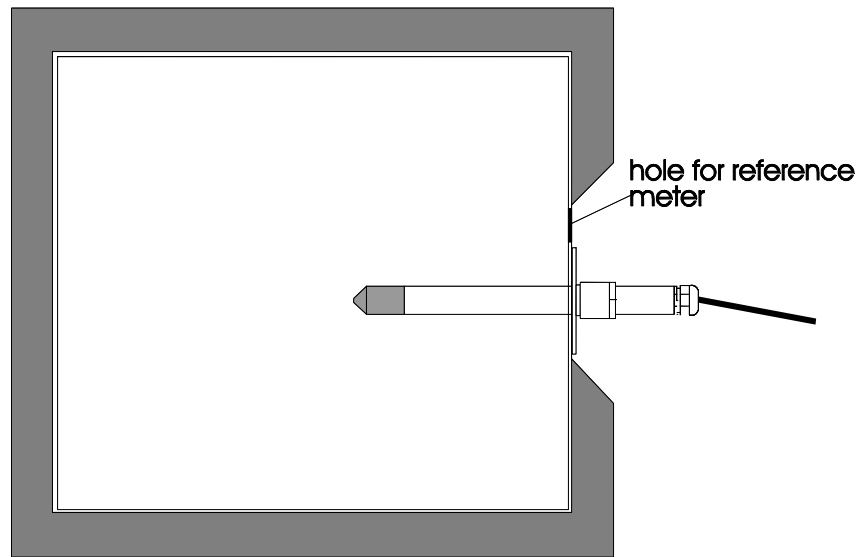

Figure 8 Mounting the sensor head on a duct or channel.

When the sensor head is installed in a duct or channel, the temperature difference between the air in the duct and outside it must be small as the sensor head conducts heat.

3.2.6. HMP237 transmitter

HMP237 has a small size probe made of stainless steel. The sensor head withstands temperatures $-40...180\text{ }^{\circ}\text{C}$ ($-40...356\text{ }^{\circ}\text{F}$) and pressure up to 10 bar (1MPa, 145 psi). The probe is suitable for applications where a mechanically very durable leak proof probe is needed. The sensor head of the HMP237 can be installed in a channel with the help of flange and supporting bar (see Figure 3). Duct and cable installations are shown in Figures 9 and 10.

Figure 9. HMP237 Duct installation.

1. Make hole with PG13 thread in the measurement chamber or process wall. The smoothness of the thread circle should be $R=6.3$ microm.
2. Install the cable gland (AGRO nr 1113.60.15) on the thread of the process wall.
3. Push the probe through the gland so deep that the backside of the probe is flush with the cable gland nut.
4. Tighten the cable gland nut, the probe will lift up slightly.

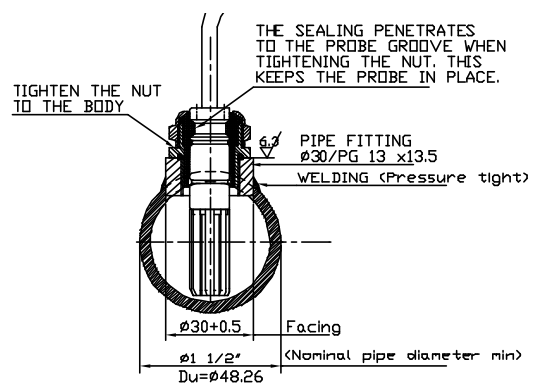

Cable gland (AGRO 1113.60.15)

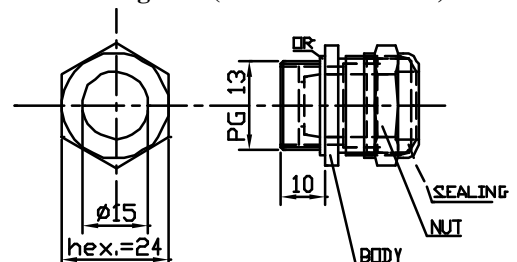

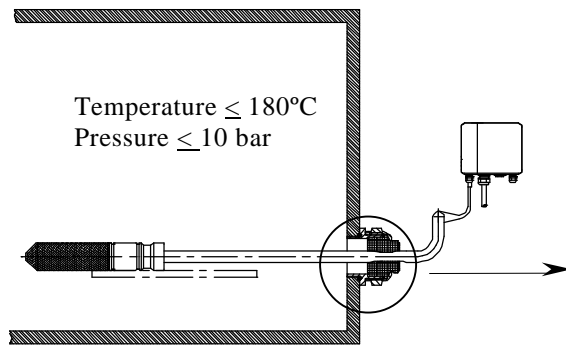

Figure 10. HMP237 cable installation.

1. Make a hole as described in duct installation, Figure 9.
2. Take out the rubber sealing from the AGRO Nr 1013.30.91. Drill a 6 mm hole in the middle of the rubber sealing. Cut the jacket of the sealing.
3. Thread the probe through the AGRO-fitting body and nut (without the cut rubber).
4. Set the cut rubber sealing through the cable between the fitting body and the nut.
5. Turn the fitting body to the hole, push the rubber sealing into the fitting body and tighten the nut.

3.2.7. HMP238 transmitter

The atmospheric pressure has an effect on mixing ratio, wet bulb temperature and enthalpy. Therefore, accurate calculations can be achieved only when the ambient pressure is taken into consideration. The pressure is used for pressure compensation of the HUMICAP sensor in order to ensure the best possible measurement accuracy. **If the process pressure differs from normal ambient pressure, the value has to be entered in the transmitter memory when using the transmitters HMP234 or HMP238.** The pressure to be entered is the absolute pressure in hPa or mbar (for pressure unit conversion, see Appendix 10).

It is recommended that the sensor head is installed directly in the process through the ball valve assembly. When the ball valve set is used, the chamber or the duct does not have to be emptied or shut down for installation or removal of the probe. Install the sensor head transversely against the direction of the process flow.

However, if direct installation is not possible for some reason, the probe can be installed in a "leak-through" position provided that there is a slight overpressure in the process. In this installation, the probe is mounted behind the ball valve assembly. The flow passes through the sensor head and leaks out through a vent hole in the fitting body. However, make sure that the temperature at the measurement point is equal to that of the process.

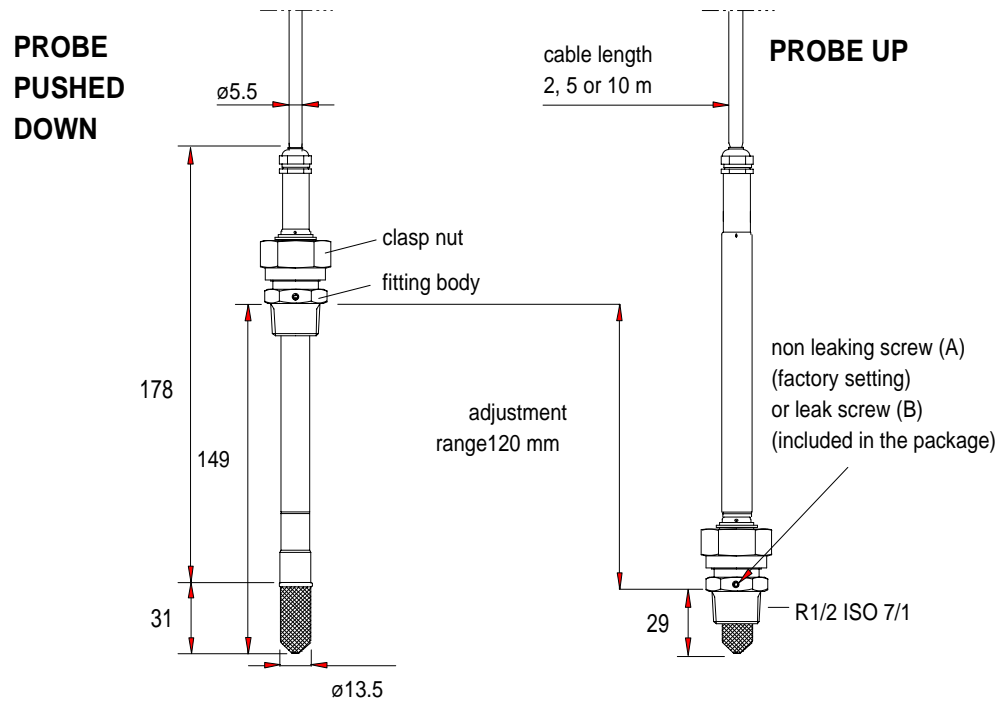

Figure 11 HMP238 Probe dimensions (in mm)

NOTE

Take care not to damage the pipe of the probe. If the pipe is damaged, the probe head is less tight and it will not go through the clasp nut.

3.2.7.1. Mounting; overview

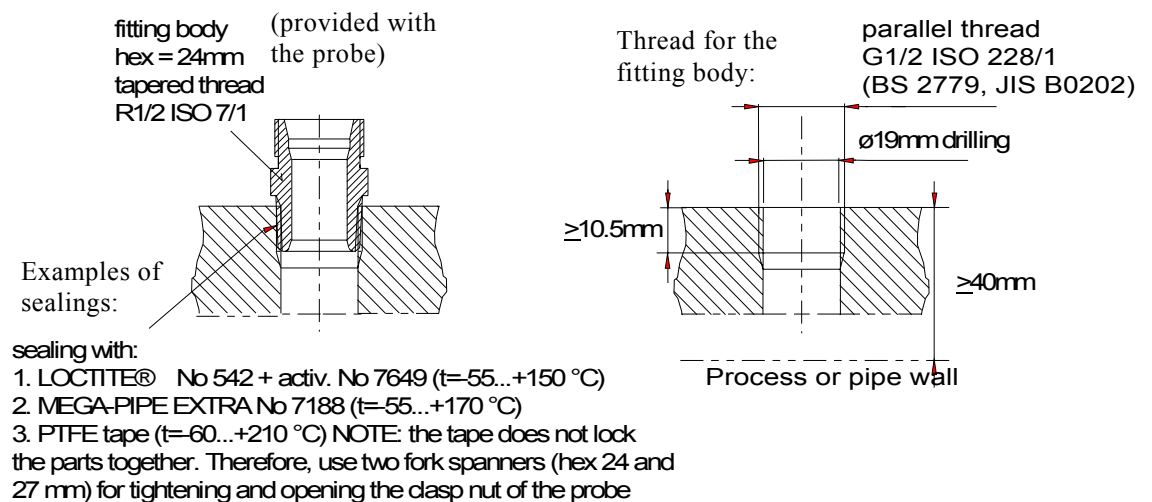

Figure 12 Sealing and thread cutting for the fitting body

The fitting body can be installed e.g. on standard pipe fittings (G 1/2 ISO 228/1) or on a thread in the process wall. If the wall thickness is more than 10.5 mm, it is recommended to use a welded sleeve (see Figure 14). Note that the minimum recommended distance of the fitting body and probe head is 40 mm (see Figure 12).

Adjust the probe to a suitable distance according to the type of installation and tighten the clasp nut first manually; mark the fitting body and the clasp nut and tighten the nut a further 50...60° with a fork spanner (see Figure 13).

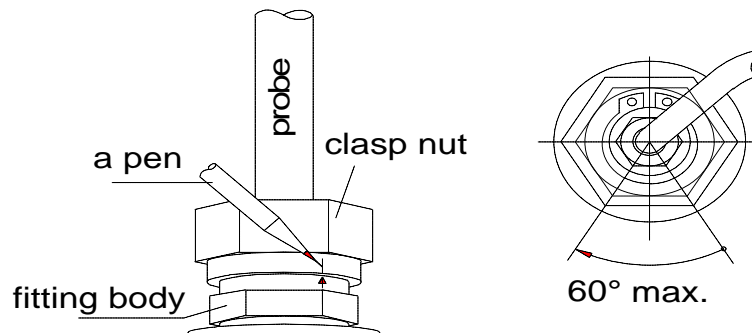

Figure 13 Tightening the clasp nut.

NOTE

Be careful not to tighten the clasp nut more than 60° as this may result in difficulties when trying to open it.

When the probe is installed directly on the process wall or pipe, note that a closing valve may be needed on both sides of the installed probe so that the sensor head can be removed from the process for calibration and maintenance.

If the sensor head is installed in a pressurized chamber, always make sure that the pressure of the chamber is equalized with the ambient pressure prior to removing the probe.

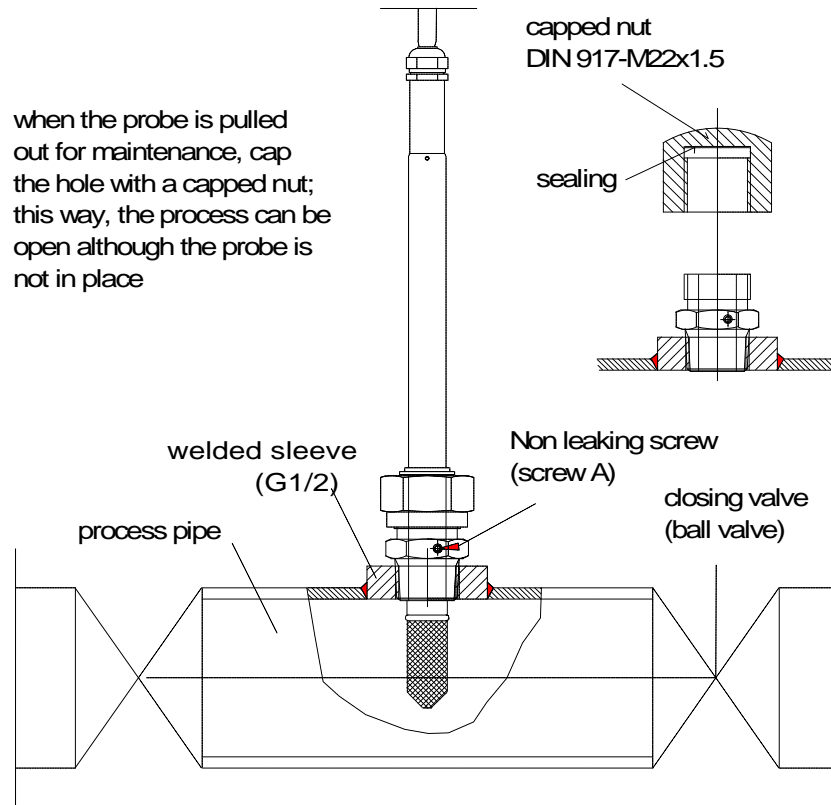

Figure 14 Installing the sensor head directly on the process wall

3.2.7.2. Installing the probe through the ball valve assembly

The best way to install the sensor head is through the ball valve assembly. Use a 1/2" ball valve assembly with a ball hole of 14 mm or more. In this kind of installation, it is not necessary to empty or shut down the process for installing or removing the sensor head. If the sensor head is installed in a process pipe, please note that the nominal size of the pipe must be at least 1 inch. See pages 16 - 19 for detailed instructions.

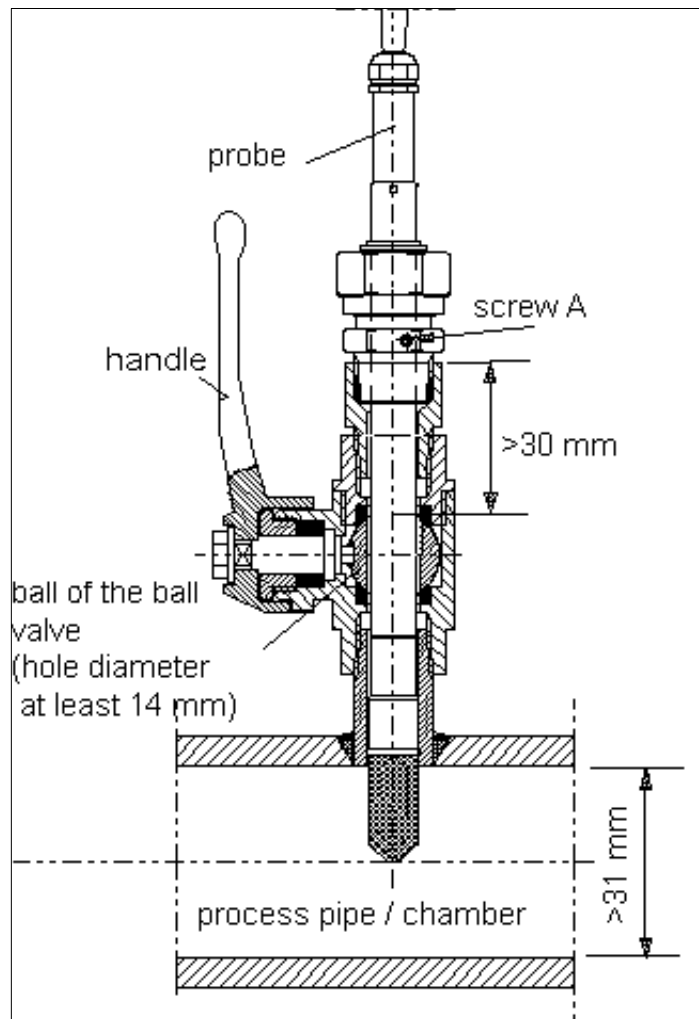

Figure 15 Installing the sensor head through the DMP248BVS ball valve assembly

NOTE

The probe can be installed in the process through the ball valve assembly provided that the process pressure is less than 10 bars. This way, the process does not have to be shut down when installing or removing the probe. However, if the process is shut down before removing the probe, the process pressure can be max. 40 bars.

See Figure 16 through Figure 18 for detailed description of installation through the ball valve assembly. **This installation is possible provided that the process pressure is less than 10 bars.** Note also that if the sensor head is installed in a process pipe, the nominal size of the pipe must be at least 1 inch.

STEP I: mount the probe with the ball valve assembly closed; tighten the clasp nut manually

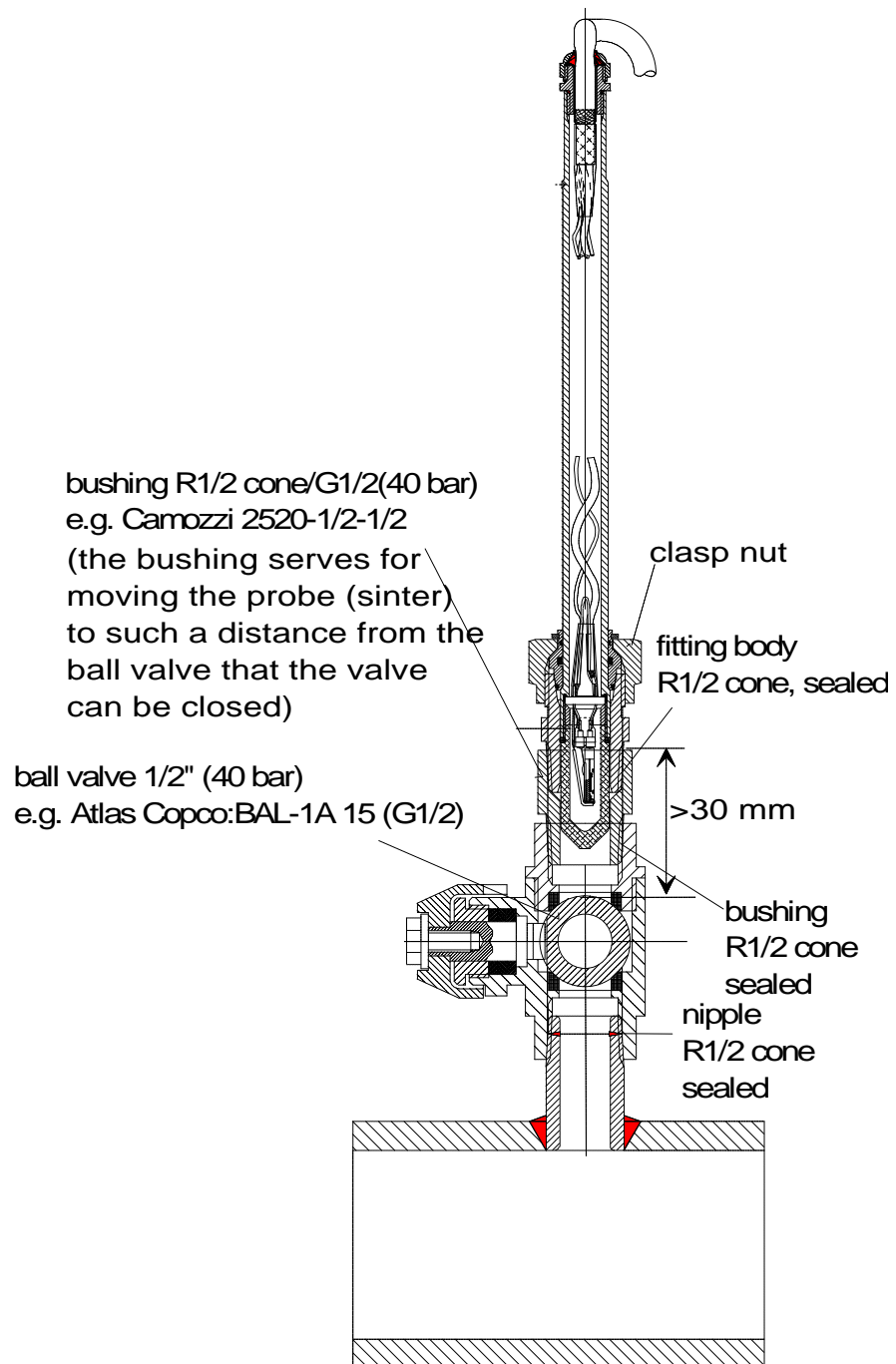

Figure 16 Installing the probe through the ball valve assembly; step 1.

STEP 2: open the ball valve assembly

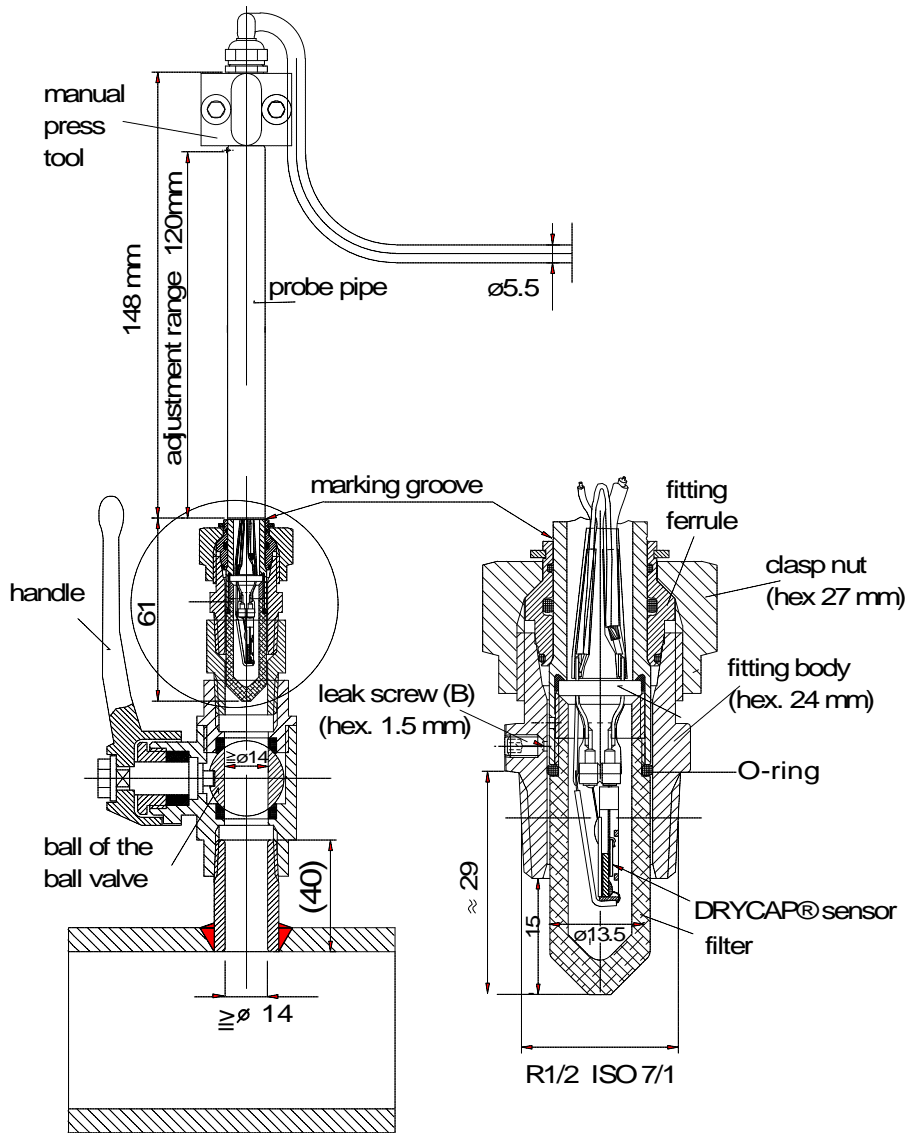

Figure 17 Installing the probe through the ball valve assembly; step 2 (measures in mm)

STEP 3: push the probe head through the ball valve assembly into the process. If the pressure is high, use a manual press tool. Note that the sensor head must be pushed so deep that the filter is completely inside the process flow.

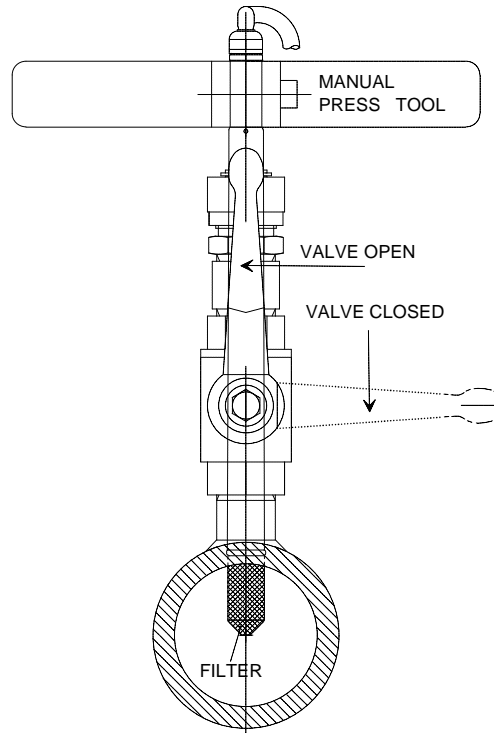

Figure 18 Installing the probe through the ball valve assembly: step 3

For by-pass measurements, the probe is mounted behind the ball valve assembly and non-leaking screw A on the fitting body is replaced with leaking screw B and O-ring is placed on the groove of the sintered filter. Screw B has a small (0.08 mm) laser-made hole in the middle; the gas or air to be measured passes through the sintered filter and by the sensor, and leaks out through the screw. The process pressure reduces in the hole of the screw B. This installation is recommended if the process flow rate is >20 m/s and there is an over-pressure in the process.

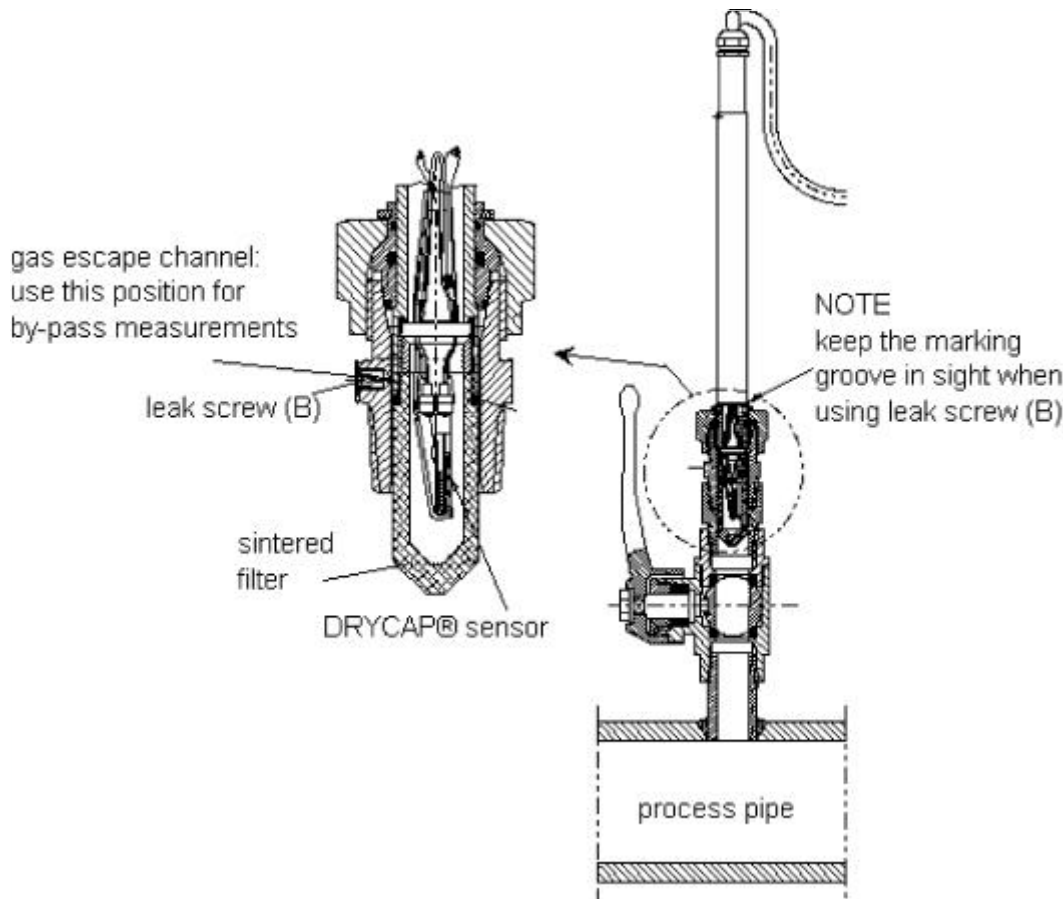

Figure 19 Installing the sensor head for by-pass measurements.

When pushing the probe head through the ball valve assembly, be careful not to break the sintered filter. Open and close the ball valve assembly with the marking groove always in sight. In by-pass measurements, the clasp nut is tightened manually prior to pressing the probe through the valve. When the probe has been pressed through and the valve is open, the nut is tightened 50...60° with a fork spanner (hexagon 27 mm).

3.3. Grounding

A single electrical cable with a screen and three to ten wires is recommended for power and analogue output/serial bus connections. The cable diameter should be 7...10 mm.

The screen of the electrical cable must be grounded properly to achieve best possible EMC performance. Recommended cable shield is done in the cable gland as shown below.

remove the brass disks, rubber ring and nut from the transmitter housing

strip 165 mm of the cable insulation, but leave 25 mm of the braid visible

slip the nut and rubber ring over the cable insulation

slip the brass disk that has the bigger hole in it over the braid so that it rests against the cable insulation

slip the other brass disk over the wires to the middle of the braid

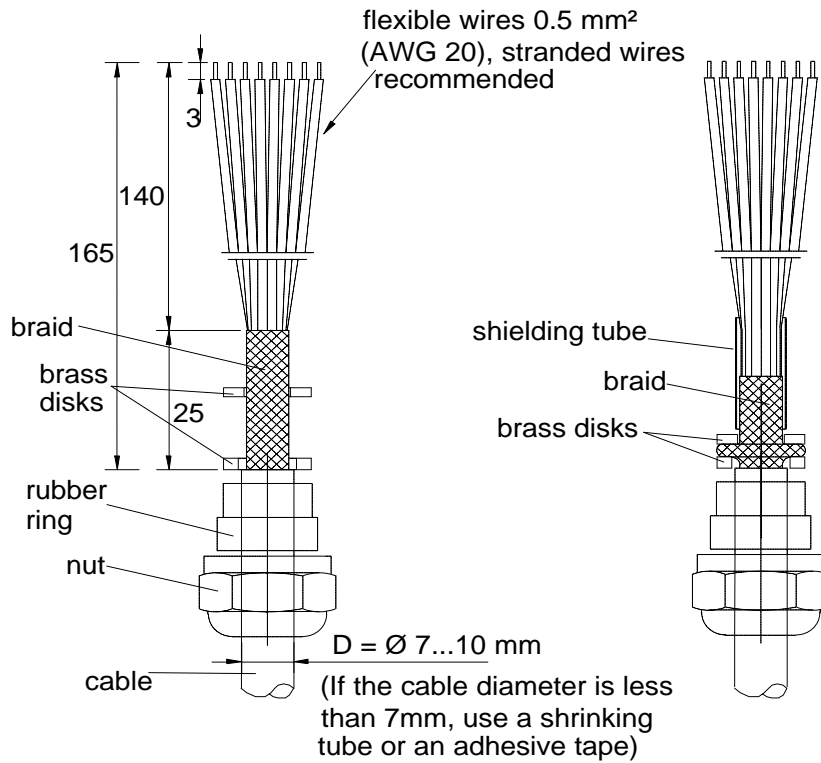

push back the braid and press it between the two brass disks to achieve a full 360° grounding; the fold between the disks should have the same diameter as the brass disks

secure the braid with a shielding tube

insert the wires into the transmitter housing through the gland.

tighten the nut

connect the wires into the screw terminals and fasten a cable tie around the wires

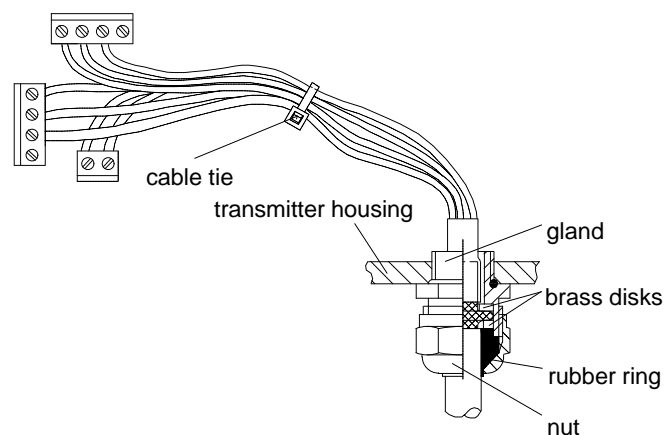

NOTE

When the cable is grounded as above, the metallic parts of the sensor head, the shield of its cable, the transmitter housing and the shield of the signal cable to external system are all connected to each other. After this the whole system can be grounded from one point only. If the grounding is made via several points (sensor head, transmitter housing, signal cable), make sure that the different groundings are made to the same grounding potential. Otherwise harmful grounding currents may be generated. If you do the grounding via the transmitter housing, use one serrated lock washer between a mounting screw and the housing; the lock washer breaks the paint on the housing.

When mains power supply is in use, the housing must be grounded by protective ground wire using a grounding screw at the right-hand side of the power supply module (see Appendix 2).

3.4. Electrical connections

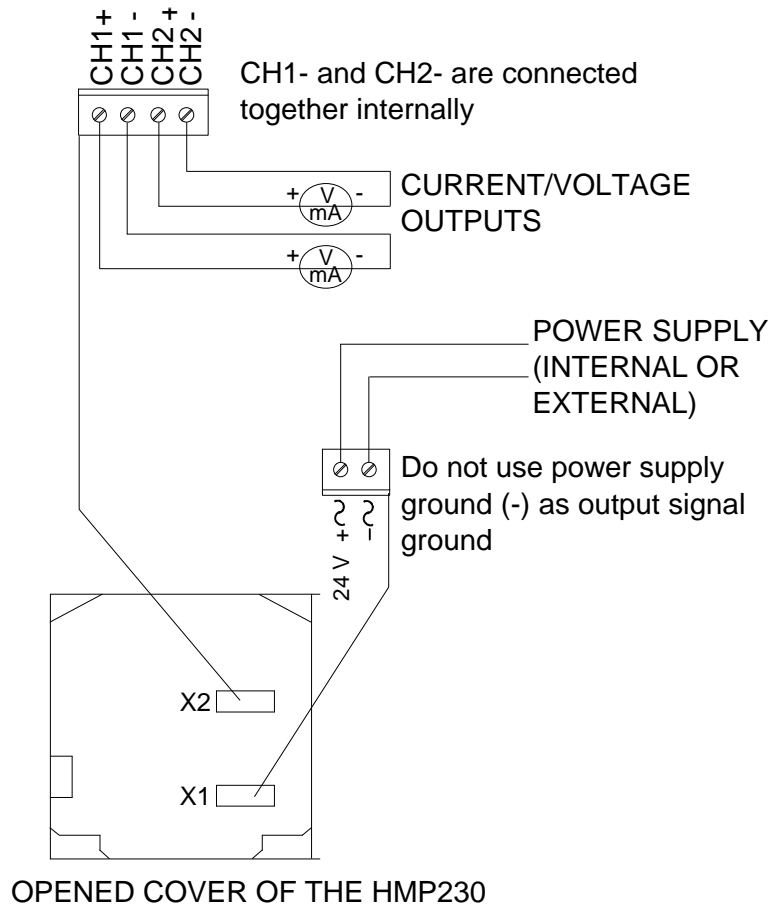

Figure 20 Electrical connections

Power supply	24 VDC 24 VAC (see page 23) 115/230 VAC
with power supply module	
Output signals	0...20 mA, 4...20 mA 0...1 V, 0...5 V, 0...10 V

Power supply ground (-) is connected to the housing with parallel connection of 15 nF capacitor and 300 k Ω resistor.

See Appendix 2 on how to connect the power supply module to the transmitter.

3.4.1. Connection to a 24 VAC supply

The HMP230 transmitters can also be connected to a 24 VAC supply without an external rectifier. However, when more than one transmitter is connected to one 24 VAC transformer, a common loop is formed and there is an increased risk of a short-circuit. To avoid this, always use separate floating supply for each transmitter (see Figure 21 A). However, if several transmitters have to share one transformer, the phase (\sim) must always be connected to + connector in each transmitter (see Figure 21 B).

A) NO COMMON LOOP FORMED - RECOMMENDED

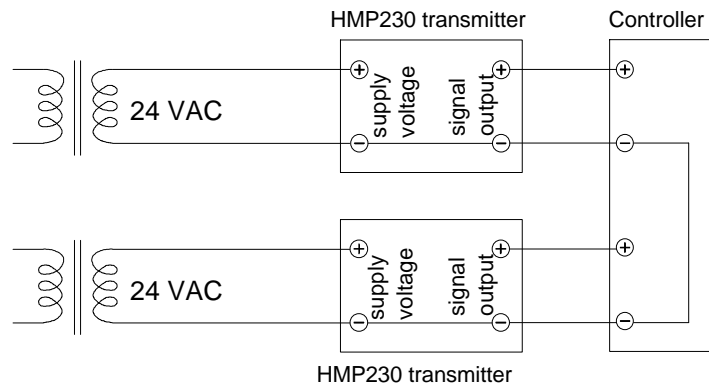

B) COMMON LOOP FORMED - NOT RECOMMENDED!

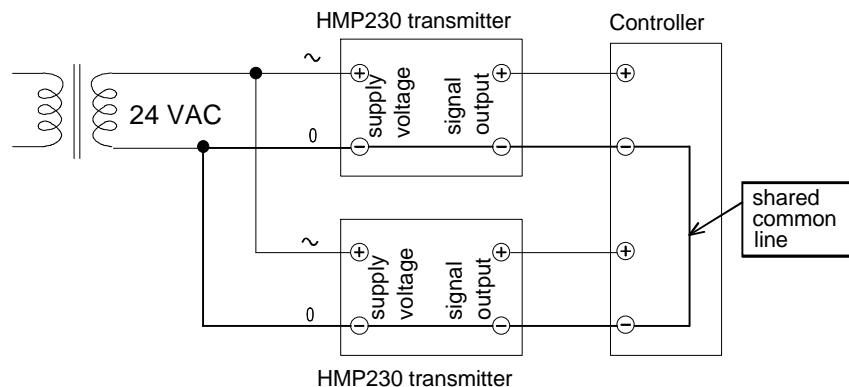

Figure 21 Connecting the transmitters to a 24 VAC supply

4. COMMISSIONING

When HMP230 transmitters leave the factory, their measurement ranges and output signals have already been scaled according to the order form completed by the customer. Units are calibrated at the factory and ready to operate when the power is turned on. If you take into use active current, voltage or serial bus outputs, make these connections first; Appendix 9 describes them in detail.

NOTE

Make sure that the power is not turned on until cables have been connected to screw terminals!

In transmitters with display, the software version appears for a few seconds when the power is turned on. After this, measurement results appear automatically. Should an error message appear on the display, consult Appendix 5.

If your transmitter has a blank cover and the LED indicator inside the housing lights up, consult Appendix 5 for further information.

Appendix 7 contains information on how to determine the ranges for alarm outputs and alarm controls when an alarm output unit is used.

4.1. Changing the parameters

If necessary, the user can subsequently change the measurement units between metric and non-metric and select and scale the output signals with software functions. This is done through commands, either utilizing the menus on the local display or giving commands through the serial interface (see Appendices). Most often the commands are used to change the settings of the two analogue channels.

4.2. Security lock jumper

Before the settings can be changed, the user must first remove the security lock jumper in connector X15 (see Figure 22). The security lock jumper makes it impossible to change the transmitter settings by mistake.

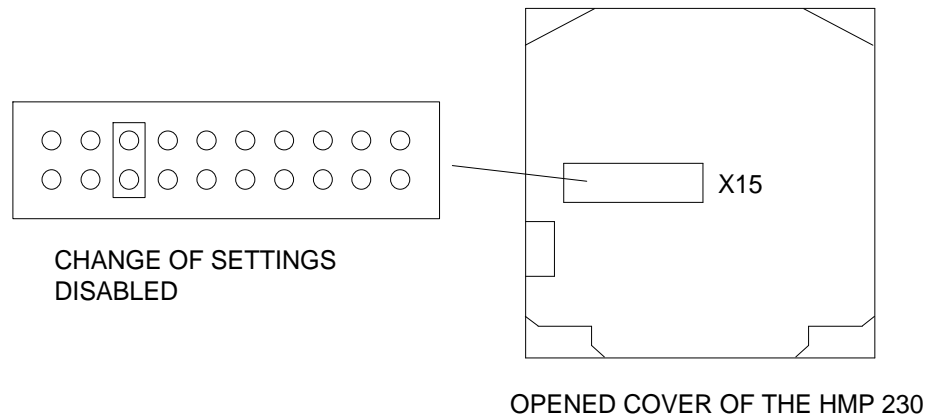

Figure 22 Location of the security lock jumper

When the security lock jumper is connected, some commands cannot be used, see Chapter 5.

If you wish to take into use variables that are not included in the configuration of your transmitter, contact Vaisala or a Vaisala representative.

4.3. Selecting the analogue outputs

The HMP230 transmitters can be ordered with the required current or voltage outputs already selected. If the outputs need to be changed, move the jumpers in connector X15 into positions as shown in Figure 23.

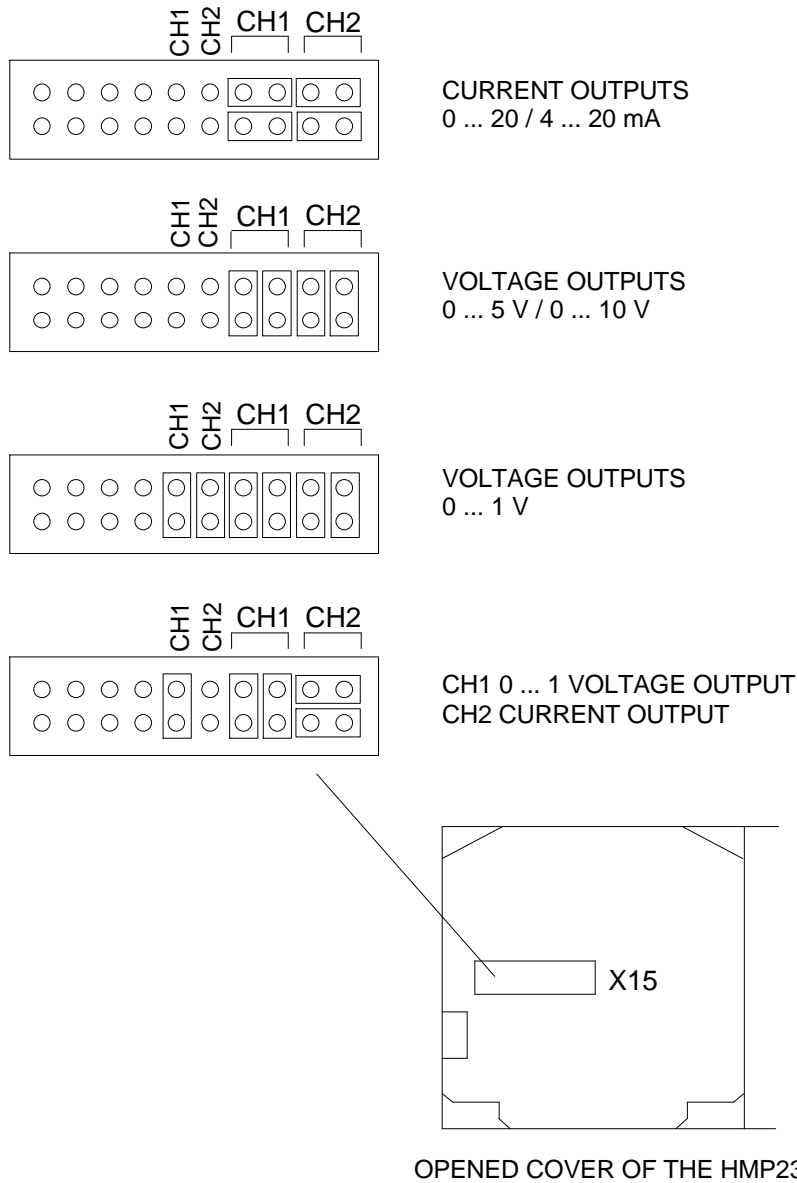
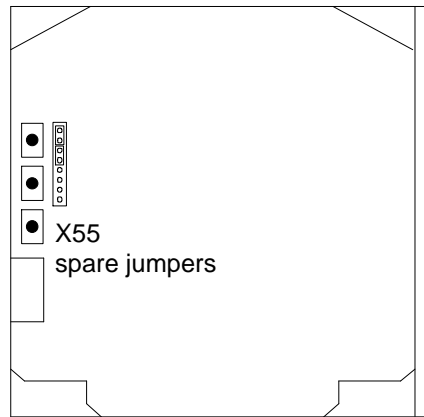

Figure 23 Selecting the analogue outputs with jumpers.

The software also has to be informed which outputs are in use. This is done either through the serial interface or the menu on local display when one is in use. The serial command is `AMODE` and the display/keypad command "Mode ⇒ Analog outputs ⇒ Mode" (see Chapter 5). If the outputs need to be scaled, see serial command `ASCL` and the display command "Mode ⇒ Analog outputs ⇒ Scale".

All jumpers are used only with the 0...1 V outputs. When other outputs are in use, the spare jumpers are kept in connector X55.



OPENED COVER OF THE HMP230

Figure 24 Spare jumpers

4.4. Connecting the RS 232C serial bus

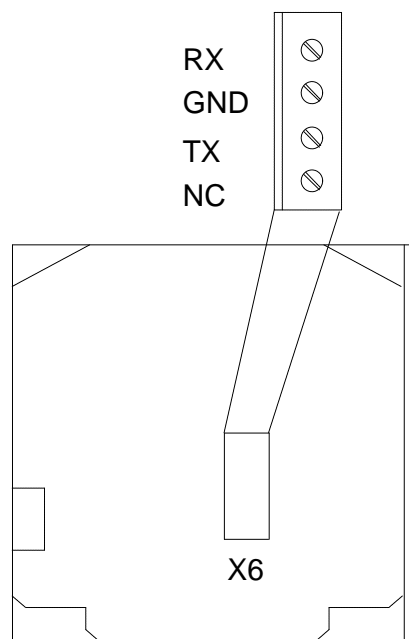

OPENED COVER OF THE HMP230

Figure 25 Serial bus connections

To connect a PC to the HMP230 transmitters via the RS 232C serial bus, one of the following cables is required. The type of cable depends on the terminal and the connector type.

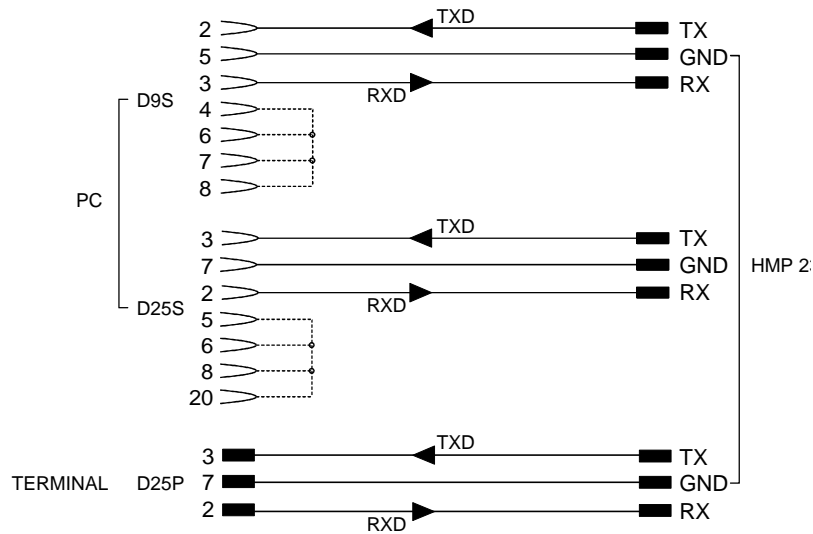

Figure 26 Connection of cables

When the serial bus has been connected between the PC and the transmitter, the PC is switched on. When using a PC, a terminal emulation program (e.g. Procomm Plus, Datastorm or Windows terminal) is started.

The factory settings for data transfer are:

- 4800 baud
- even parity
- 7 data bits
- 1 stop bit
- full duplex

NOTE

When the serial bus settings are changed, the transmitter has to be reset before the new settings become effective.

The processor does not allow the following combinations:

- no parity, 7 data bits, 1 stop bit: if this combination is given the HMP230 program will change the number of stop bits to 2
- even or odd parity, 8 data bits, 2 stop bits: if this combination is given the program changes the number of stop bits to 1

Refer to the manuals of the PC and the terminal emulation program when giving serial settings.

The RS 232C screw terminal cannot be used if an RS 485/422 serial module or a current loop module is used. See Appendices 3 and 4 on how to install and operate these modules.

In calibrating or changing the settings of the transmitter it can be more convenient to use the connector X17, if connector X6 is already in use. This connector, however, transfers only RS 232C signals. If an RS 485/422 serial port module or a current loop module has been installed, it has to be removed before communicating through the X17 connector.

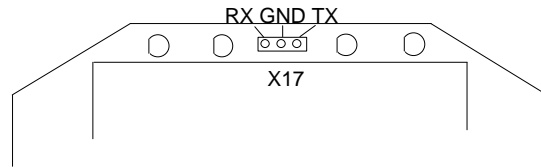

Figure 27 Location and connections of connector X17

NOTE

Some PC computers can generate interferences to the measured humidity and temperature values if the transmitter and the PC are connected to different mains outlets. To minimize the possibility of these interferences, always use the same mains outlet (same phase of the mains electricity) for the PC and the power supply of HMP230. This is especially the case when using the serial line connector X17. The serial line connector X6 is more immune to these interferences than connector X17.

4.4.1. Reverting to factory settings of the serial port

If the serial port settings are not known, no commands can be given via the serial interface. The settings can be reverted to the factory settings by inserting a jumper in connector X16. The jumper must be inserted when the power is on!

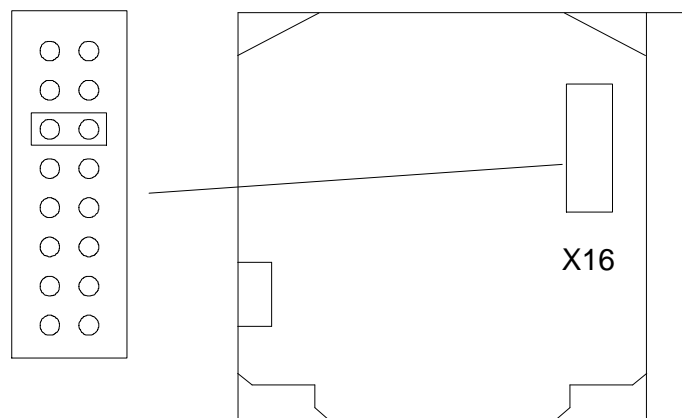

OPENED COVER OF THE HMP230

Figure 28 Forcing the serial port settings back to factory settings

When the jumper is inserted the serial line factory settings become valid, but only temporarily. **The transmitter must be given new settings; otherwise the transmitter uses the old, unknown settings after power-up.** When the new settings have been given, the transmitter must be reset. The jumper must be removed before the transmitter is reset; if the jumper is in place when power is turned on, the transmitter does not work.

After jumper insertion the transmitter is in STOP mode, ready to receive commands.

The same method is used when the transmitter is in POLL mode and the user has forgotten its address.

CAUTION

Inserting a jumper in any other place in connector X16 voids the guarantee of the transmitter.

5. CONNECTION TO PC

Connect a serial connection cable to the appropriate connectors on your PC and in the HMP230 (see Appendix 11, connector X6).

5.1. Giving the communication parameters

Give the communication parameters when using this terminal session for the first time; save them for future use. See instructions in the following tables.

Giving parameters in Windows 3.1

MENU	DESCRIPTION
PROGRAM MANAGER	
↓	
ACCESSORIES	double click
↓	
TERMINAL	double click
↓	
Settings	click
↓	
Communications	click and select parameters (see figure on next page); click OK
↓	move the cursor to:
File	click
↓	
Save as	click and save settings: type the name of the file and click OK

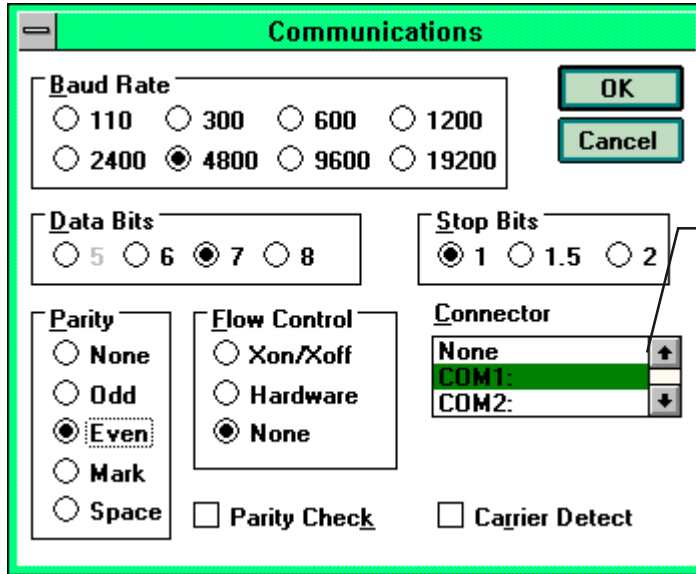

NOTE: select the connector according to your computer. Select the connector first and give then other parameters

Giving the communication parameters in Windows 3.1

Giving parameters in Windows 95 and Windows NT

WINDOWS 95		WINDOWS NT	
MENU	WHAT TO DO	MENU	WHAT TO DO
Start		Start	
↓	move the cursor to:	↓	move the cursor to:
Programs		Programs	
↓	move the cursor to:	↓	move the cursor to:
Accessories		Accessories	
↓	move the cursor to:	↓	move the cursor to:
HyperTerminal	click	HyperTerminal	
↓	move the cursor to:	↓	move the cursor to:
Hypertrm	double click	Hyperterminal	click
↓		↓	
Connection Description	type the name of the connection in the appropriate field and select an icon if available; click OK.	Connection Description	type the name of the connection in the appropriate field and select an icon if available; click OK.
↓			
Phone Number	move the cursor to the field CONNECT USING and select ' direct to COM x ' (x = serial port available); click OK	Connect to	move the cursor to the field CONNECT USING and select ' COM x ' (x = serial port available); click OK
↓		↓	
COM x properties	select parameters according to the previous figure; click OK	COM x properties	select parameters according to the previous figure, click OK

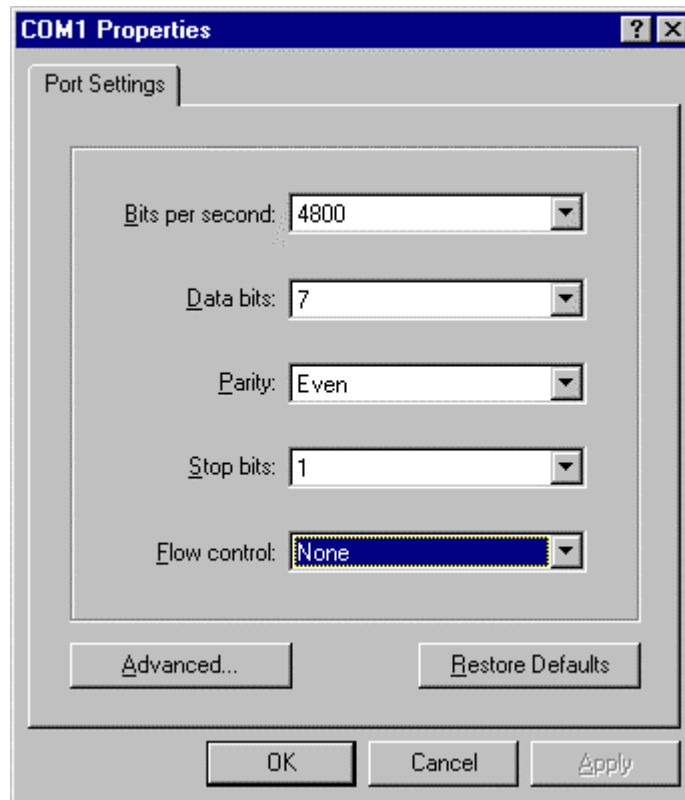

Selecting the parameters in Windows 95 and NT

6. COMMANDS

The HMP230 transmitters use microprocessors; therefore their configuration can be set according to the user's needs. This is done through commands, either utilizing the menus on the local display or giving commands through the serial interface (see Appendix 1). Most often the commands are used to change the settings of the two analogue channels.

A limited range of commands can be given by using the three press switches - up, down and enter - inside the transmitter housing. Four LEDs indicate the command given with the up and down switches. The switches and LEDs are in all HMP230 transmitters. LED commands can be used to calibrate the transmitters (both humidity and temperature) or to calibrate the analogue outputs.

A full range of commands can be given through the display/keypad or through the RS 232C serial bus. The commands can be used e.g. to select and scale the outputs, to calibrate the humidity and temperature channels as well as the analogue outputs and to set the serial interface.

6.1. Commands and security lock jumper

In order to prevent any tampering with the transmitter settings, the transmitters cannot be calibrated, the analogue outputs set or the analogue output quantities selected or scaled unless the security lock jumper has been disconnected. The commands involved are:

all LED commands

display/keypad commands:

Cali	⇒	RH cal	T cal		
		Analog outputs			
Mode	⇒	Analog outputs	⇒	Mode	
				Scale	
More	⇒	More	⇒	Frost	
More	⇒	Filt			

serial commands:

CRH, CT, CTA, FCRH, ACAL; AMODE, ASEL, ASCL, FROST, FILT

In the following, the description of these functions is preceded with a reminder of the security lock jumper:

Disconnect the security lock jumper!

6.2. LED commands

NOTE

If the transmitter has a display/keypad cover, the LED commands cannot be used.

LED commands can be used to operate the transmitters in the field. These commands can be used in humidity and temperature calibration and calibration of the analogue outputs.

Open the housing and press any one of the three press switches. The LEDs will light up for 2...3 seconds.

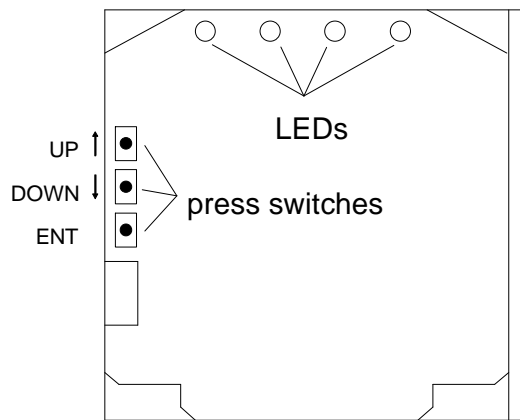

OPENED COVER OF THE HMP230

Figure 29 Location of press switches and LEDs

Use the up and down switches (marked with arrows on the printed board) to find the desired command code and acknowledge it with the ENT switch. The command codes are (● = lit, ○ = dark):

- | | | |
|------|-----|---|
| ○○○○ | (0) | return to normal state |
| ○○○● | (1) | relative humidity calibration |
| ○○●○ | (2) | temperature calibration |
| ○○●● | (3) | calibration of analogue outputs |
| ●○○○ | (8) | relative humidity calibration after sensor change |

6.3. Display/keypad commands

6.3.1. Display mode

In the display mode the transmitters output measurements on the display; different quantities can be scrolled with the arrow keys according to the variables selected when ordering the transmitter. The first line is scrolled with button and the second line with button . All selections are stored with ENTER. The selected quantities appear on the display also after power failure. After reset the transmitters are always in the display mode.

The display also shows error messages and alarms if they occur.

6.3.2. Command mode

Press the CL key to enter the command mode. The first display is the main menu:



```
Mode Seri Unit  
Cali Addr More
```

The commands can be scrolled with arrow keys. The currently active command flashes; a command is selected with the ENT key. When a menu is displayed, either the first command or the currently valid setting flashes. The CL key takes the transmitter back to the display mode.

6.3.3. Entering numbers

When the transmitter needs numbers to be entered into the program (e.g. when scaling or setting the analogue outputs, in calibration or when giving the transmitter an address), the field is either empty or the currently valid figure is displayed. Any previously given value is deleted with the CL key.

When the field is empty, a cursor blinks at the right side of the display. Pressing the arrow keys brings either a blank (), a comma (,), a dash (-), a full stop (.) or a number from 0 to 9 on the display. The right character is selected with ENT; after that the number or numbers move left one step. Entering numbers is ended with selecting a blank () and pressing ENT. The last character entered can be deleted with CL. If CL or ENT key is pressed when the field is empty, the program returns to the previous display.

With some commands (e.g. calibration) the figures are changed using the arrow keys. When an arrow key is pressed continuously for a while, the numbers start changing at an increasing rate.

6.3.4. Analogue output commands

6.3.4.1. Selecting the output (mA/V)

Disconnect the security lock jumper!

Select Mode in the main menu and Analog outputs in the Mode menu:

```
Mode ( mA / V )
Scale
```

Select Mode (mA / V). The current settings for channel 1 are displayed:

```
Ch1 mA      20.00
    0.00
```

If the settings are correct, press ENT.

If the settings need to be changed, press CL:

the quantity (mA/V) starts flashing; it can be changed with the arrow keys and acknowledged with the ENT key

the lower limit starts flashing

acknowledge the lower limit with ENT or start changing it by pressing CL; a new lower limit is given one character at a time with the arrow keys

the upper limit starts flashing

acknowledge the upper limit with ENT or start changing it by pressing CL; a new upper limit is given one character at a time with the arrow keys

When channel 1 has been set, the program goes on to channel 2; the procedure is the same as with channel 1.

```
Ch2 mA      20.00
    4.00
```

NOTE

Also the analogue output jumpers must be set to correct places (see Figure 23).

6.3.4.2. Selecting and scaling the analogue output quantities

Disconnect the security lock jumper!

Select Mode in the main menu and Analog outputs in the Mode menu:

```
Mode ( mA / V )  
Scale
```

Select Scale. The quantity and scaling for channel 1 are displayed:

```
Ch1 RH  %RH  
0.00  100.00
```

If the settings are correct, press ENT.

If the settings need to be changed, press CL:

the quantity (RH, T, Td, x, a, Tw, h) starts flashing; it can be changed with the arrow keys and acknowledged with the ENT key

the lower limit starts flashing

acknowledge the lower limit with ENT or start changing it by pressing CL; a new lower limit is given with the arrow keys

the upper limit starts flashing

acknowledge the upper limit with ENT or start changing it by pressing CL; a new upper limit is given with the arrow keys

When channel 1 has been set, the program goes on to channel 2; the procedure is the same as with channel 1.

```
Ch2 T  °C  
-40.00  160.00
```

Please note that the selections that are possible are affected by the choice of output parameters. Also make sure that the temperature measuring ranges are not exceeded, e.g. the HMP231 cannot be used in temperatures above +60 °C.

6.3.5. Output via the serial bus

6.3.5.1. Turning the serial interface echo ON/OFF

Select More in the main menu, select More in the More menu and select Echo in the second More menu.

```
Echo on
Echo off
```

Use the arrow keys to select the right alternative and press ENT.

6.3.5.2. Serial bus settings

Select Seri in the main menu; the currently valid serial interface settings are displayed:

```
Baud:4800 Data:1
Pari:even Stop:1
```

If the settings are correct, press ENT; the program returns to the display mode.

If the settings need to be changed, press CL:

```
Baud Pari Stop
Data Duplex
```

Select the parameter to be changed with the arrow keys and ENT key.

Selecting baud rate:

```
300 600 1200
2400 4800 9600
```

Selecting parity:

```
None Even Odd
```

Selecting data bits:

```
7 data bits
8 data bits
```

Selecting stop bits:

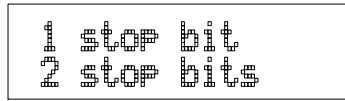

Full duplex/half duplex:

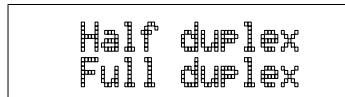

The processor does not allow the following combinations:

no parity, 7 data bits, 1 stop bit: if this combination is given the HMP230 program will change the number of stop bits to 2

even or odd parity, 8 data bits, 2 stop bits: if this combination is given the program changes the number of stop bits to 1

NOTE

The serial bus settings become effective only after reset.

6.3.5.3. Setting the transmitter address

Address is used when more than one transmitter is connected to one serial bus; this way, it is possible to communicate with one transmitter at a time.

Select Addr in the main menu; the following is displayed:

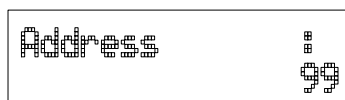

Pressing ENT returns the program to the main menu.

Pressing CL deletes the old address; enter the new address with the arrow keys.

6.3.5.4. Selecting the output units

Select Unit in the main menu:

```
metric
non metric
```

Use the arrow keys to select the right alternative and press ENT.

quantity	metric	non-metric
RH = relative humidity	%RH	%RH
T = temperature	°C	°F
Td = dewpoint temperature	°C	°F
a = absolute humidity	g/m ³	gr/ft ³
x = mixing ratio	g/kg	gr/lb
h = enthalpy	kJ/kg	Btu/lb
Tw = wet bulb temperature	°C	°F

6.3.5.5. Selecting the calculation mode

Disconnect the security lock jumper!

Select More and then again More in the second menu:

```
ReSen Echo Mtin
Frost Test
```

Select Frost and then the desired alternative with the arrow keys; FROST ON for frostpoint and FROST OFF (default) for dewpoint calculation at dewpoint temperatures below 0 °C.

6.3.6. Output modes

The output modes only affect output through the serial interface: the transmitter accepts all display and LED commands irrespective of which serial output mode it is in. The HMP230 transmitters have three serial output modes: RUN, STOP and POLL.

In the RUN state the transmitter outputs measurements automatically through the serial interface to a PC or a peripheral. The only command that can be given through the serial interface is S (stop), which ends the RUN state.

In the STOP state serial commands are given to the transmitters. Measurements are then output only by entering command SEND.

The POLL state is used when more than one transmitter is connected to the same serial bus; a single transmitter can be addressed and communicated with. When the connection to the one transmitter is opened in the POLL state, the transmitter goes into STOP state and can receive commands normally. Closing

the connection returns the transmitter to POLL state. In POLL state the transmitter outputs measurement only when requested (command SEND aa). If the user has forgotten the address of the transmitter and the transmitter does not have a display, the transmitter has to be reverted to the factory settings (see Chapter 4.4.1). If the transmitter has a display, the settings can be checked through it.

6.3.6.1. Setting the serial interface operation mode

Select Mode in the main menu; the following is displayed:

```
Serial output
Analog outputs
```

Select Serial output:

```
Stop Run Poll
```

The currently valid setting flashes. Select the desired mode with the arrow keys and press ENT. After this the program returns to the Mode Menu.

When RUN mode is selected, the currently valid output interval is displayed:

The output interval setting can be changed as follows:

```
Output interval
255 hour
```

press CL

the number starts flashing

if the interval needs to be changed, press CL again and enter the new interval; otherwise press ENT

the unit (s, min, h) starts flashing

the unit can be changed with the arrow keys and acknowledged with ENT

after this the program returns to Mode menu

6.3.7. Others

6.3.7.1. Setting the averaging time

Disconnect the security lock jumper!

With command FILT the transmitter can be given the averaging time during which the individual measurement samples are integrated to get an averaged reading. The time can be set in seconds within the range of 0 - 1024 (0 = no averaging time = factory setting).

Select More in the main menu and select FilT in the More menu:

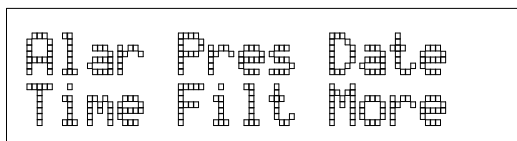

The LCD display shows the main menu with the following options: Alar Pres Date, Time FilT More.

Pressing ENT returns the program to the main menu without changing the filtration time.

If the filtration time needs to be changed, press CL; enter the new filtration time with the arrow keys.

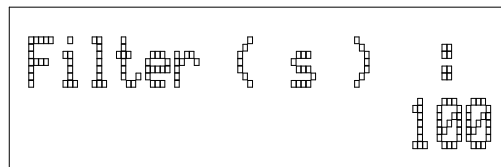

The LCD display shows the FILT (s) menu with the value 100.

6.3.7.2. Setting the pressure for pressure compensation of the HUMICAP^â sensor and for mixing ratio, wet bulb and enthalpy calculations

The atmospheric pressure has an effect on mixing ratio, wet bulb temperature and enthalpy. Therefore, accurate calculations can be achieved only when the ambient pressure is taken into consideration. The pressure is used for pressure compensation of the HUMICAP^â sensor in order to ensure the best possible measurement accuracy. If the process pressure differs from normal ambient pressure, the value has to be entered in the transmitter memory when using the transmitters HMP234 or HMP238. The pressure to be entered is the absolute pressure in hPa or mbar (for pressure unit conversion, see Appendix 10).

NOTE

The pressure compensation takes place only with the security lock jumper connected. If the security lock jumper is not connected, the pressure compensation is performed with the value 1013.25 hPa.

Select More in the main menu:

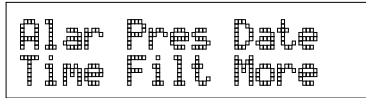

Alar Pres Date
Time Filt More

Select Pres:

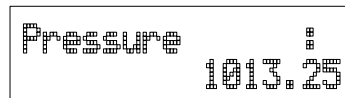

Pressure :
1013.25

Pressing ENT returns the program to the main menu without changing the pressure reading.

If the pressure needs to be changed, press CL; enter the new pressure with the arrow keys

6.3.7.3. Setting the date

Select More in the main menu; select Date in the More menu:

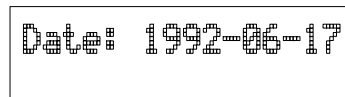

Date: 1992-06-17

If the date is correct, acknowledge it by pressing ENT; this takes the program back to the More menu.

If the date needs to be changed, press CL.

first the centuries (19) start flashing; use the arrow keys to change them and press ENT

the years (92) start flashing; use the arrow keys to change them and press ENT

the months (06) start flashing; use the arrow keys to change them and press ENT

the days (17) start flashing; use the arrow keys to change them and press ENT

6.3.7.4. Setting the time

Select More in the main menu; select Time in the More menu:

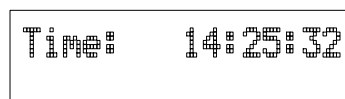

Time: 14:25:32

If the time is correct, acknowledge it by pressing ENT; this takes the program back to the More menu.

If the time needs to be changed, press CL.

first the hours (14) start flashing; use the arrow keys to change them and press ENT

the minutes (25) start flashing; use the arrow keys to change them and press ENT

the seconds (32) start flashing; use the arrow keys to change them and press ENT

NOTE

The transmitter does not have a real-time clock with backup battery. This means that the date and time settings are not permanent.

6.4. Serial commands

More detailed descriptions of the serial commands can be found in Appendix 1. Here only the most commonly used command sequences are described. The instructions on how to connect the HMP230 transmitters to serial bus are given in Chapter 4.4.

Pressing ESC always interrupts any serial command being given. In the commands <cr> means carriage return.

6.4.1. Analogue output commands

6.4.1.1. Setting the analogue outputs

Disconnect the security lock jumper!

AMODE a bb.bbb cc.ccc d ee.eee ff.fff <cr>

a = channel 1: U = voltage output
 I = current output
bb.bbb = lower limit of channel 1
cc.ccc = upper limit of channel 1
d = channel 2: U = voltage output
 I = current output
ee.eee = lower limit of channel 2
ff.fff = upper limit of channel 2

The bb.bbb, cc.ccc, ee.eee and ff.fff parameters are entered in volts or milliamperes.

Example: lower limit of channel 1 is 0 V and upper limit 1 V (U 0 1)
 lower limit of channel 2 is 2 V and upper limit 10 V (U 2 10)

```
>AMODE U 0 1 U 2 10 <cr>  
Ch1 : 0.000 ... 1.000 V  
Ch2 : 2.000 ... 10.000 V
```

6.4.1.2. Selecting and scaling the analogue output quantities

Disconnect the security lock jumper!

ASEL xxx yyy <cr>

xxx	=	channel 1's quantity
yyy	=	channel 2's quantity:
		RH = relative humidity
		T = temperature
		Td = dewpoint temperature
		Abs = absolute humidity
		Mix = mixing ratio
		h = enthalpy
		Tw = wet bulb temperature

Example: relative humidity selected on channel 1 and temperature on channel 2

```
>ASEL RH T <cr>
Ch1(RH)      lo  0.000 %RH      ? <cr>
Ch1(RH)      hi 100.000 %RH      ? <cr>
Ch2(T )      lo -40.000 'C       ? <cr>
Ch2(T )      hi +160.000 'C      ? <cr>
```

6.4.1.3. Scaling the analogue outputs

Disconnect the security lock jumper!

ASCL <cr>

Example: relative humidity is scaled on the range of 0...100 %RH and temperature -40...+160 °C

```
>ASCL <cr>
Ch1(RH)      lo  0.000 %RH      ? <cr>
Ch1(RH)      hi 100.000 %RH      ? <cr>
Ch2(T )      lo  0.000 'C       ?  -40 <cr>
Ch2(T )      hi 100.000 'C      ?  160 <cr>
```

6.4.2. Output via the serial bus

6.4.2.1. Starting the measurement output

R <cr>

Starts output of measurements to the peripheral devices (RUN mode); the only command that can be used is S (stop).

The output mode can be changed with command FORM (see Appendix 1).

6.4.2.2. Stopping the measurement output

S<cr>

Ends the RUN mode; after this command all other commands can be used.

6.4.2.3. Outputting the reading once

SEND <cr> in STOP mode

or

SEND aa <cr> in POLL state

aa = address of the transmitter when more than one transmitter is connected to a serial bus (0...99)

The output format depends on which parameters the transmitter can output.

Output types:

```
RH= 21.9 %RH T= 23.9 'C  
RH= 21.9 %RH T= 23.9 'C Td=0.9 'C  
RH= 21.9 %RH T=23.9 'C a=4.7 g/m3 x=4.0 g/kg Tw= 12.3 'C  
RH= 21.9 %RH T= 23.9 'C Td=0.9 'C a=4.8 g/m3 x=4.0 g/kg  
Tw=12.3 'C h=34.4 kJ/kg  
RH= 21.9 %RH T= 24.0 'C h= 34.4 kJ/kg
```

The output mode can be changed with command FORM (see Appendix 1).

6.4.2.4. Setting the output interval for the RUN mode

```
INTV xxx yyy <cr>
```

xxx = output interval (0...255)
 0: no pause between outputs
 yyy = unit (s, min or h)

Example: output interval is changed into 10 minutes

```
>INTV 10 min <cr>
Output intrv. : 10 min
```

6.4.2.5. Serial bus settings

```
SERI b p d s x <cr>
```

b = bauds (300, 600, 1200, 2400, 4800, 9600)
 p = parity (n = none, e = even, o = odd)
 d = data bits (7 or 8)
 s = stop bits (1 or 2)
 x = duplex (H = half, F = full)

The settings can be changed one parameter at a time or all parameters at once:

```
>SERI 0 <cr>                changing parity only
4800 0 7 1 HDX

>SERI 600 N 8 1 F <cr>     changing all parameters
600 N 8 1 FDX
```

The processor does not allow the following combinations:

no parity, 7 data bits, 1 stop bit: if this combination is given the HMP230 program will change the number of stop bits to 2

even or odd parity, 8 data bits, 2 stop bits: if this combination is given the program changes the number of stop bits to 1

NOTE

The serial bus settings become effective only after reset.

When the half-duplex mode is set, it will automatically turn the echo off. Even then the ECHO command can indicate that echo is on.

6.4.2.6. Selecting the output units

UNIT x <cr>

x = m(etric units)
 n(on-metric units)

quantity	metric	non-metric
RH = relative humidity	%RH	%RH
T = temperature	°C	°F
Td = dewpoint temperature	°C	°F
a = absolute humidity	g/m ³	gr/ft ³
x = mixing ratio	g/kg	gr/lb
h = enthalpy	kJ/kg	Btu/lb
Tw = wet bulb temperature	°C	°F

6.4.2.7. Setting the averaging time

Disconnect the security lock jumper!

FILT nnnn <cr>

nnn = averaging time (0 - 1024 seconds)

This command is used to set and inspect the averaging time during which the individual measurement samples are integrated to get an averaged reading. The time can be set in seconds within the range of 0 - 1024 (0 = no averaging time).

For example:

```
>FILT
Filter (S):  0 ? 1024
>

>FILT 100 <cr>
Filter (S):  100
>
```

6.4.2.8. Setting the transmitter address

ADDR aa <cr>

aa = address (0...99)

Example: transmitter is given address 99

```
>ADDR <cr>
Address : 2 ? 99 <cr>
```

6.4.2.9. Setting the calculation mode

Disconnect the security lock jumper!

FROST ON/OFF <cr>

This command is used to select whether the transmitter calculates the frostpoint or the dewpoint (default) reading at dewpoint temperatures below 0 °C. Select FROST ON for frostpoint and FROST OFF for dewpoint calculations. For example:

```
>Frost <cr>
Frost : ON
>Frost off
Frost : OFF
>Frost on
Frost : on
>
```

6.4.2.10. Resetting the transmitter

RESET <cr>

6.4.3. Operating the transmitter via the serial bus

6.4.3.1. Setting the serial interface

SMODE xxxx<cr>

xxxx = STOP, RUN or POLL

In STOP mode: measurements output only by command, all commands can be used

In RUN mode: outputting automatically, only command S can be used

In POLL mode: measurements output only with command SEND. When in POLL state, the output state is changed as follows:

OPEN aa <cr>
SMODE xxxx<cr>

aa = address of the transmitter
xxxx = STOP, RUN or POLL

The OPEN command sets the bus temporarily in STOP state so that the SMODE command can be given.

Example:

```
>SMODE STOP <cr>          setting STOP state
Serial mode : STOP
```

6.4.3.2. OPEN & CLOSE

OPEN nn <cr>

nn = address of the transmitter (0...99)

CLOSE <cr>

In STOP mode: command OPEN has no effect, CLOSE sets the transmitter in POLL mode

In POLL mode: command OPEN sets the transmitter temporarily in STOP mode, command CLOSE returns the instrument to POLL mode

Example: relative humidity calibration is performed at transmitter 2 which is in POLL state

```
>OPEN 2 <cr>          opens the line to transmitter 2
>CRH <cr>             calibration started
...
>CLOSE <cr>          line closed
```

7. CALIBRATION

The HMP230 transmitters have been fully calibrated at the factory and there should be no immediate need to calibrate them again. The transmitters should be calibrated only if there is reason to believe that the adjustments of the transmitter have changed. The adjustments of the temperature measurement channel and the analogue outputs are particularly stable and in normal circumstances there is no need to recalibrate them. It is recommended that humidity calibration is performed at least once a year. See the chapter 10 Factory calibration and repair service.

7.1. Humidity calibration

The calibration of the HMP230 transmitters can be checked with a calibrated Vaisala humidity meter, such as the HM34. The HMI41 indicator or the HMI38 data processor with an appropriate reference connection cable can be used as a field calibrator. A two-point calibration can be made with the HMK15 or with the HMK13B Calibrator or the instrument can be sent to Vaisala. We recommend recalibration at least once a year. The instruments must be recalibrated every time the HUMICAP humidity sensor is changed.

When calibrating with the HMK13B calibrator, an adapter is necessary (part no. 16611). Calibration can be performed by giving the commands using the press switches inside the housing, through the serial bus or through the menus on the local display.

When LED commands are used and when the two analogue channels do not output relative humidity and/or temperature, relative humidity is calibrated on channel 1 and temperature is calibrated on channel 2. The calibration ranges are 0...100 %RH and -20...+80 °C. When the transmitters are calibrated at two points, the points must be either 50 %RH or 50 °C apart from each other.

NOTE

If the transmitter includes the re-gaining option, the sensor re-gaining must always be made before humidity calibration. Before starting the calibration, make sure that the temperature of the composite sensor has come down to ambient temperature (see Appendix 9).

7.1.1. One point calibration procedure

The HMI38 humidity data processor or the HMI41 indicator can be used as a one-point field calibrator. Two point calibration using the HMI38 is also possible if two different humidity points (differing more than 50 %RH from each other) can be provided. The HMI38 is connected to an HMP230 transmitter using an appropriate reference connection cable. The necessary correction factors are automatically stored in the HMP230 memory. Detailed calibration instructions are given in the HMI38 operating manual.

A one-point correction can also be done manually in the field against an accurate reference.

NOTE

If the sensor has been changed, the calibration has to be done according to the instructions in Chapter 7.1.3.

7.1.1.1. With serial commands

Make sure that the sensors of the transmitter and the reference instrument are close to each other. Allow enough time for the sensor heads to stabilize to the measurement conditions.

Disconnect the security lock jumper!

Give command CRH <cr>, enter the humidity value and press <cr>.

```
>CRH <cr>  
RH : xx.x Ref1 ? yy.y <cr>  
Press any key when ready...
```

If you want to see how the sensor stabilizes to the reference humidity enter c <cr> instead of the first reference:

```
RH : 11.9 Ref1 ? c <cr>  
RH : 11.5 Ref1 ? c <cr>  
RH : 11.5 Ref1 ? 11.3 <cr>  
Press any key when ready...
```

Press any key and press <cr> when the transmitter requests the second point value.

```
RH : yy.y Ref2 ? <cr>
```

7.1.1.2. With display/keypad commands

Make sure that the sensors of the transmitter and the reference instrument are close to each other. Allow enough time for the sensor heads to stabilize to the measurement conditions.

Disconnect the security lock jumper!

Select Cali in the main menu and then RH cal; select Not changed and then one-point offset correction RH 1 point cal. Change the humidity reading with the arrow keys to correspond to the reference value and acknowledge it with ENT; pressing an arrow once changes the reading by 0.05 %RH.

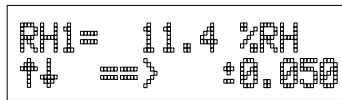

The image shows a monochrome LCD display with two lines of text. The top line reads "RH= 11.4 %RH". The bottom line shows a cursor (a vertical bar) positioned at the decimal point of the offset value "0.050".

7.1.1.3. With LED commands

Make sure that the sensors of the transmitter and the reference instrument are close to each other. Allow enough time for the sensor heads to stabilize to the measurement conditions.

Disconnect the security lock jumper!

Connect an ammeter/voltmeter to the analogue outputs (connector X2); if the outputs are already connected e.g. to a process computer and you do not want to disconnect them, the current output can be measured at separate test points located next to connector X15 (see Chapter 8.5). Give command ○○○● (see Chapter 6.2). At the first calibration point the LED on the left flashes; adjust the humidity point (offset) with the arrow switches to the reference value. One push of a switch changes the output by 0.05 %RH; the change of the output voltage or current depends on the output scaling. Press ENT switch. The second LED from left starts flashing; press ENT again.

7.1.2. Two point calibration procedure

A two-point humidity calibration should be performed in stable conditions using saturated salt solutions as references.

NOTE

If the sensor has been changed, the calibration has to be done according to the instructions in Chapter 7.1.3.

7.1.2.1. With serial commands

Leave the calibrator and the transmitter for at least 4 hours in the same space so that their temperatures have time to equalize. Remove the filter cap on the transmitter.

Disconnect the security lock jumper!

Insert the sensor head into a measurement hole of the LiCl chamber in the humidity calibrator.

Wait at least 30 minutes.

Give command CRH <cr>, enter the first point value and press <cr>.

```
>CRH <cr>  
RH : xx.x Ref1 ? yy.y <cr>  
Press any key when ready...
```

If you want to see how the sensor stabilizes to the humidity in the calibrator, enter c <cr> instead of the first reference:

```
RH : 11.9 Ref1 ? c <cr>  
RH : 11.5 Ref1 ? c <cr>  
RH : 11.5 Ref1 ? 11.3 <cr>  
Press any key when ready...
```

Insert the sensor head into a measurement hole of the NaCl chamber.

Wait at least 30 minutes.

Press any key and enter the second point value and press <cr>.

```
RH : xx.x Ref2 ? yy.y <cr>
```

The stabilization of the sensor can be monitored by entering c <cr> instead of the reference value.

7.1.2.2. With display/keypad commands

Leave the calibrator and the transmitter for at least 4 hours in the same space so that their temperatures have time to equalize. Remove the filter cap on the transmitter.

Disconnect the security lock jumper!

Insert the sensor head into the measurement hole of the LiCl chamber.

Wait at least 30 minutes.

Select Cali in the main menu and then RH cal; select Not changed and then two-point calibration RH 2 point cal. Change the first point reading with the arrow keys to correspond the reference humidity and press ENT; pressing an arrow once changes the reading by 0.05 %RH.

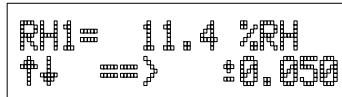

Insert the sensor head into a measurement hole of the NaCl chamber.

Wait at least 30 minutes.

If necessary, change the second point reading with the arrow keys and press ENT.

7.1.2.3. With LED commands

Leave the calibrator and the transmitter for at least 4 hours in the same space so that their temperatures have time to equalize. Remove the filter cap on the transmitter.

Disconnect the security lock jumper!

Insert the sensor head into a measurement hole of the LiCl chamber.

Wait at least 30 minutes.

Connect an ammeter/voltmeter to the analogue outputs (connector X2). Give command ○○○●. At the first calibration point the LED on the left flashes; adjust the first point (offset) with the arrow switches to the value given in the calibration table (Chapter 7.1.4) and press ENT switch.

Insert the sensor head into a measurement hole of the NaCl chamber.

Wait at least 30 minutes.

Check that the reading corresponds within the desired accuracy to that given in the calibration table (Chapter 7.1.4). If not, adjust the second point with the arrow switches to the correct value and press ENT. At the second calibration point the second LED from the left flashes.

7.1.3. Calibration procedure after sensor change

Humidity calibration should be performed in stable conditions using saturated salt solutions as a reference.

7.1.3.1. With serial commands

Leave the calibrator and the transmitter for at least 4 hours in the same space so that their temperatures have time to equalize. Remove the filter cap on the transmitter.

Disconnect the security lock jumper!

Insert the sensor head into a measurement hole of the LiCl chamber.

Wait at least 10 minutes.

Give command FCRH <cr>, enter the first point value and press <cr>:

```
>FCRH <cr>  
RH : xx.x Ref1 ? yy.y <cr>  
Press any key when ready...
```

The stabilization of the sensor to the reference humidity can be monitored by giving c <cr>:

```
RH : 11.9 Ref1 ? c <cr>  
RH : 11.5 Ref1 ? c <cr>  
RH : 11.5 Ref1 ? 11.3 <cr>  
Press any key when ready...
```

Insert the sensor head into a measurement hole of the NaCl chamber.

Wait at least 30 minutes.

Press any key and enter the second point value and press <cr>.

```
RH : xx.x Ref2 ? yy.y <cr>
```

The stabilization of the sensor can be monitored by entering c <cr> instead of the reference value.

7.1.3.2. With display/keypad commands

Leave the calibrator and the transmitter for at least 4 hours in the same space so that their temperatures have time to equalize. Remove the filter cap on the transmitter.

Disconnect the security lock jumper!

Insert the sensor head into a measurement hole of the LiCl chamber.

Wait at least 30 minutes.

Select Cali in the main menu and then RH cal; select Sensor changed. Change the first point reading with the arrow keys and press ENT.

Insert the sensor head into a measurement hole of the NaCl chamber.

Wait at least 30 minutes.

If necessary, change the second point reading with the arrow keys and press ENT.

7.1.3.3. With LED commands

Leave the calibrator and the transmitter for at least 4 hours in the same space so that their temperatures have time to equalize. Remove the filter cap on the transmitter.

Disconnect the security lock jumper!

Insert the sensor head into a measurement hole of the LiCl chamber.

Wait at least 30 minutes.

Connect an ammeter/voltmeter to the analogue outputs (connector X2). Give command ●○○○. At the first calibration point the LED on the left flashes; adjust the first point with the arrow switches to the value given in the calibration table (Chapter 7.1.4) and press ENT switch.

Insert the sensor head into a measurement hole of the NaCl chamber.

Wait at least 30 minutes.

Check that the reading corresponds within the desired accuracy to that given in the calibration table (Chapter 7.1.4). If not, adjust the second point with the arrow switches to the correct value and press ENT. At the second calibration point the second LED from the left flashes.

The basic capacitance of the new sensor may differ considerably from that of the previous one. Therefore, the corresponding humidity reading of the transmitter may be below 0 %RH at the low or above 100 %RH at the high calibration point. However, the current/voltage reading of the analogue output shows only the minimum or maximum value of the selected current/voltage scale and the output value may not change even though the arrow switches are pressed several times. If this happens, press the up or down arrow switch continuously to bring the output back into the selected scale; this may take as long as half a minute.

7.1.4. Humidity calibration table

Table 1 Greenspans's calibration table

Temperature	°C	15	20	25	30	35
	°F	59	68	77	86	95
LiCl	%RH	*	11.3	11.3	11.3	11.3
4...20 mA			5.81	5.81	5.81	5.81
0...20 mA			2.26	2.26	2.26	2.26
0...1 V			0.113	0.113	0.113	0.113
0...5 V			0.565	0.565	0.565	0.565
0...10 V			1.13	1.13	1.13	1.13
NaCl	%RH	75.6	75.5	75.3	75.1	74.9
4...20 mA		16.10	16.08	16.05	16.02	15.98
0...20 mA		15.12	15.10	15.06	15.02	14.98
0...1 V		0.756	0.755	0.753	0.751	0.749
0...5 V		3.780	3.775	3.765	3.755	3.745
0...10 V		7.56	7.55	7.53	7.51	7.49

*) If the LiCl solution is used or stored at temperatures below +18 °C (+64 °F), the equilibrium humidity of the salt solution changes permanently.

7.2. Temperature calibration

The temperature channel has been calibrated at the factory and since it is very stable, calibration should be performed only when there is strong reason to believe that the adjustments have changed.

Temperature calibration should be done against some accurate temperature reference. It can be done either using the press switches inside the housing, through the serial bus or the menus on the local display. Either a one point offset correction or a two point calibration is possible.

7.2.1. One point offset correction

7.2.1.1. With serial commands

Leave the reference instrument and the transmitter for at least 4 hours in the same space so that their temperatures have time to equalize. Remove the filter cap prior to calibration.

Disconnect the security lock jumper!

Check the transmitter against the reference.

Give command CT <cr>, enter the first point value and press <cr>:

```
>CT <cr>  
T : xx.x Ref1 ? yy.y <cr>  
Press any key when ready
```

If you want to see how the sensor stabilizes to the reference temperature, enter `c <cr>` instead of the first reference:

```
T : 0.90 Ref1 ? c <cr>
T : 0.55 Ref1 ? c <cr>
T : 0.55 Ref1 ? 0.0 <cr>
Press any key when ready...
```

After giving the correct temperature value (Ref1) and pressing `<cr>`, press any key and press `<cr>`.

7.2.1.2. With display/keypad commands

Leave the reference instrument and the transmitter for at least 4 hours in the same space so that their temperatures have time to equalize. Remove the filter cap prior to calibration.

Disconnect the security lock jumper!

Check the transmitter against the reference.

Select `Cali` in the main menu and then `T cal`; select one-point calibration `T 1 point cal`.

Change the reading with the arrow keys to correspond to the reference and press `ENT`.

7.2.1.3. With LED commands

Leave the reference instrument and the transmitter for at least 4 hours in the same space so that their temperatures have time to equalize. Remove the filter cap prior to calibration.

Disconnect the security lock jumper!

Check the transmitter against the reference.

Connect an ammeter/voltmeter to the analogue outputs (connector X2). Give command `○○●○`. At the first calibration point the LED on the left flashes; adjust the first point (offset) with the arrow switches to the same reading with the reference and press `ENT` switch.

After adjusting the offset point and pressing `ENT` the second LED from left flashes. Press `ENT` without changing the output value.

7.2.2. Two point temperature calibration

7.2.2.1. With serial commands

Leave the reference instrument and the transmitter for at least 4 hours in the same space so that their temperatures have time to equalize. Remove the filter cap prior to calibration.

Disconnect the security lock jumper!

Check the transmitter against the lower reference.

Give command CT <cr>, enter the first point value and press <cr>:

```
>CT <cr>
T : xx.x Ref1 ? yy.y <cr>
Press any key when ready
```

If you want to see how the sensor stabilizes to the reference temperature, enter c <cr> instead of the first reference:

```
T : 0.90 Ref1 ? c <cr>
T : 0.55 Ref1 ? c <cr>
T : 0.55 Ref1 ? 0.0 <cr>
Press any key when ready...
```

Change the temperature and check the transmitter against the higher reference.

Check that the reading corresponds with the reading of the reference instrument. If not, adjust the second point

Press any key, enter the second point value and press <cr>.

```
T : xx.x Ref2 ? yy.y <cr>
```

The stabilization of the sensor can be monitored by entering c <cr> instead of the reference value.

7.2.2.2. With display/keypad commands

Leave the reference instrument and the transmitter for at least 4 hours in the same space so that their temperatures have time to equalize. Remove the filter cap prior to calibration.

Disconnect the security lock jumper!

Check the transmitter against the lower reference.

Select Cali in the main menu and then T cal; select two-point calibration T 2 point cal. Change the first point reading with the arrow keys and press ENT.

Change the temperature and check the transmitter against the higher reference.

Check that the reading corresponds with the reading of the reference instrument. If not, adjust the second point.

If necessary, change the second point reading with the arrow keys and press ENT.

7.2.2.3. With LED commands

Leave the reference instrument and the transmitter for at least 4 hours in the same space so that their temperatures have time to equalize. Remove the filter cap prior to calibration.

Disconnect the security lock jumper!

Check the transmitter against the lower reference.

Connect an ammeter/voltmeter to the analogue outputs (connector X2). Give command `○○●○`. At the first calibration point the LED on the left flashes; adjust the first point (offset) with the arrow switches to the same reading with the reference and press ENT switch.

If necessary, adjust with the arrow switches to the correct value and press ENT. At the second calibration point the second LED from the left flashes.

Change the temperature and check the transmitter against the higher reference.

Check that the reading corresponds with the reading of the reference instrument. If not, adjust the second point.

7.3. Calibration of the analogue outputs

The analogue outputs have been calibrated at the factory and since they are very stable, calibration of the outputs should be performed only when there is reason to believe that their adjustments have changed.

7.3.1. With serial commands

Disconnect the security lock jumper!

`ACAL <cr>`

The outputs on channels 1 and 2 are measured and the measured values (mA or V) entered as calibration coefficients.

Example: both channels have 0...10 V outputs (set with AMODE command); enter the voltages measured at the analogue outputs:

```
>ACAL <cr>  
Ch1    U1 ( V ) ? 2.233 <cr>  
Ch1    U2 ( V ) ? 8.25 <cr>  
Ch2    U1 ( V ) ? 2.218 <cr>  
Ch2    U2 ( V ) ? 8.23 <cr>
```

7.3.2. With display/keypad commands

Disconnect the security lock jumper!

Connect an ammeter/voltmeter to the output of channel 1, select Cali in the main menu and Analog outputs in the Cali menu. The following is displayed (the quantity can be either mA or V):

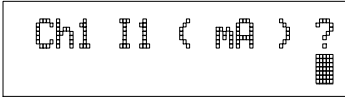

```
Ch1 I1 ( mA ) ?
```

Enter the measured lower end current/voltage on channel 1.

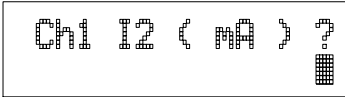

```
Ch1 I2 ( mA ) ?
```

Enter the measured upper end current/voltage on channel 1.

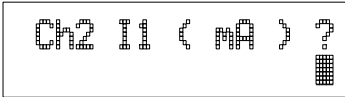

```
Ch2 I1 ( mA ) ?
```

Connect the meter to the output of channel 2 and enter the measured lower end current/voltage on channel 2.

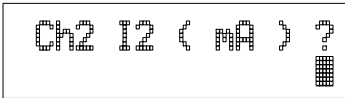

```
Ch2 I2 ( mA ) ?
```

Enter the measured upper end current/voltage on channel 2.

7.3.3. With LED commands

If both the analogue outputs and humidity/temperature channels are calibrated, the analogue outputs should be calibrated first. This applies only when the calibrations are made using the LED commands!

connect an ammeter/voltmeter to the analogue outputs (connector X2)

Disconnect the security lock jumper!

Give command ○○●●.

the LED on the left flashes; set the low end of channel 1 with the arrow keys and press ENT

the second LED from the left flashes; set the high end of channel 1 with the arrow keys and press ENT

the LED on the left flashes; set the low end of channel 2 with the arrow keys and press ENT

the second LED from the left flashes; set the high end of channel 2 with the arrow keys and press ENT

The analogue outputs are calibrated to ensure that outputs are correctly scaled: for example, when the output is scaled to 4...20 mA, the low end of the scale is 4 mA and high end 20 mA exactly. However, when 0... 20 mA output is used, the output cannot be adjusted to exactly 0 mA, but to 50 μ A. When 0...1 V, 0...5 V or 0...10 V output is in use, the output is adjusted to 50 mV. The following table summarizes the correct output values.

Summary of the correct output values:

	Output scale:				
	0...20 mA	4...20 mA	0...1 V	0...5 V	0...10 V
low end:	50 μ A	4 mA	50 mV	50 mV	50 mV
high end:	20 mA	20 mA	1 V	5 V	10 V

8. MAINTENANCE

8.1. Reference measurements

Reference measurements are needed to verify whether the transmitter readings are within specifications. This way the user can check if the transmitter needs calibration or service.

The reference meter should preferably use the same technology as the instrument checked, i.e. transmitters with capacitive sensors should be checked with instruments using capacitive sensors. This minimizes the risk of errors caused by different measurement techniques.

Whatever technique is used, make sure the reference instrument is at the same temperature as the checked instrument in order to avoid errors caused by temperature differences. The reference measurement should be made as close to the checked sensor as possible and the readings should be read at the same time, when possible.

The best reference measurements are made in laboratories. If it is possible to take the transmitter out of process or control system, make the reference measurement in a laboratory where the conditions are stable.

8.2. Self-diagnostics

The HMP230 transmitters go through a self-diagnostics procedure when the power is switched on. If the procedure does not reveal any errors or faults, the transmitter starts operating normally. If errors or faults are found, check first whether the humidity and temperature sensors are damaged. If they are intact, send the transmitter to Vaisala or a Vaisala representative for repairs. The error messages the transmitter outputs are listed in Appendix 5.

If any errors occur during operation, the error messages are output on the local display if the transmitter displays measurements; if the menus are used, error messages are not output. The LEDs indicate errors at all times. During operation, however, the error messages are not output automatically through the serial interface. If there is any reason to doubt that there is something wrong with the transmitter, use command ERRS:

```
ERRS <cr>
```

If there are no error messages, only a prompt is displayed:

```
>ERRS <cr>  
>
```

When errors have occurred, the transmitter outputs the error code (see Appendix 5 for all error messages):

```
>ERRS <cr>
E40 f ( all ) out of range
>
```

8.3. Changing the HUMICAP® sensor and the filter

Remove the damaged sensor and insert a new one. Handle the sensor by the plastic socket. **DO NOT TOUCH THE SENSOR PLATE.** After sensor change the humidity calibration must be made according to the instructions in Chapter 7.1.3.

Replace a dirty membrane or sintered filter to ensure a maximum lifetime for the sensor. Do not try to clean the filter. The sensor can be cleaned with distilled water; if this does not work, replace the sensor.

8.4. Temperature channel adjustment with Pt 100 simulators

Switch the power off and disconnect the wires to the Pt 100 sensor from solder lugs TP5, TP6 and TP7.

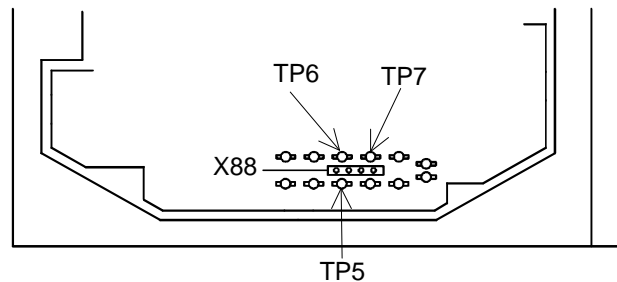

Figure 30 Location of solder lugs TP5, TP6 and TP7 and connector X88

Connect a Pt 100 simulator to connector X88 and set it at the lowest temperature to be calibrated.

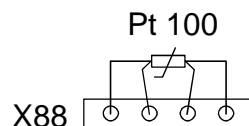

Figure 31 Connecting the Pt 100 simulator to connector X88

Switch the power on.

8.4.1. Adjustment using serial commands

Give command CT, enter the first point value and press <cr>:

```
>CT <cr>
'C : xx.x Refl ? yy.y <cr>
Press any key when ready
```

Set the Pt 100 simulator at the highest temperature to be calibrated and press any key. Enter the second point (gain) reference reading. If second reference is not needed, press <cr> to complete one point offset correction.

8.4.2. Adjustment using display commands

Select Cali in the main menu and then T cal; select two-point calibration T 2 point cal. Change the first point reading with the arrow keys and press ENT.

Set the Pt 100 simulator at the highest temperature to be calibrated and adjust the second point (gain) to the reference reading. If there is no second reference, press ENT to complete one point offset correction.

8.4.3. Adjustment using LED commands

Connect an ammeter/voltmeter to the analogue outputs (connector X2). Give command ○○●○ and adjust the first point (offset) with the arrow switches to the same reading with the reference and press ENT switch.

Set the Pt 100 simulator at the highest temperature to be calibrated and adjust the second point (gain) to the reference reading. If there is no second reference, press ENT to complete one point offset correction.

Disconnect the Pt 100 simulator and reconnect the Pt 100 wires to solder lugs TP5, TP6 and TP7.

The correct connections according to the wire colours for different transmitters are:

	TP5	TP6	TP7	TP8
HMP231	green	green	brown	brown
HMP233(120°C)/234/ 235/238	blue	green	yellow	black
HMP233 (80°C)	blue	white or green	yellow	red or black

If there is not a Pt 100 simulator available, the adjustment can be made with two resistors of 84 and 154 whose resistance is known precisely. Measure the resistor with a resistance meter. Look up the corresponding temperature value from a Pt 100 conversion table or calculate it using the following equation:

$$T = D0 + R \times \{D1 + R \times [D2 + R \times (D3 + R \times D4)]\}$$

where

$$\begin{aligned} D0 &= -243.5673014 \\ D1 &= 2.278542701 \\ D2 &= 0.002050681 \\ D3 &= -6.15025E-06 \\ D4 &= 1.34949E-08 \end{aligned}$$

8.5. Measurement of output currents using test points

If a current output has been connected e.g. to a process computer, the output current cannot be measured at the output connector X2 without disconnecting the external load. The output current can, however, be measured at test points CH1+/CH1- and CH2+/CH2- without disconnecting the output wires. These test points can therefore be used in one point offset correction against an accurate reference or in checking the current output without disconnecting the analogue output from the process.

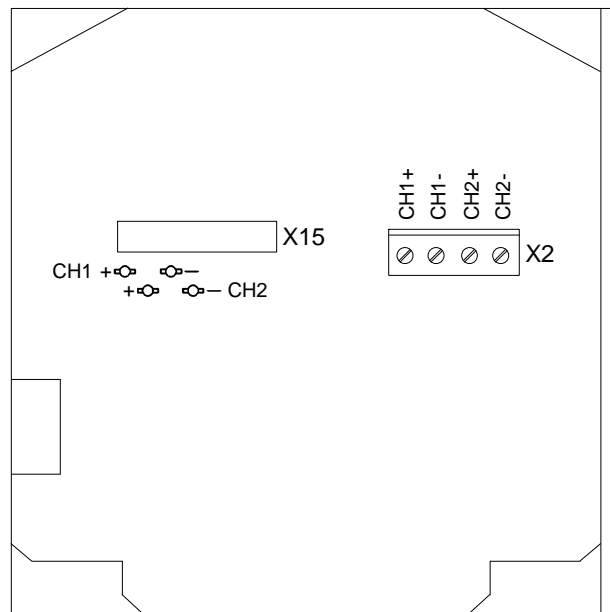

OPENED COVER OF THE HMP230

Figure 32 Location of the CH1 and CH2 test points

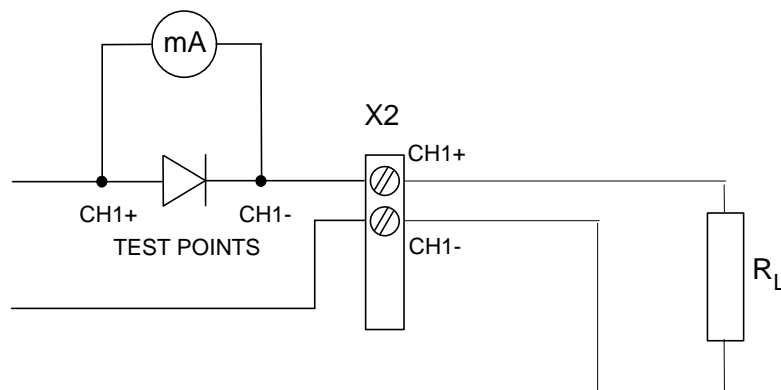

Figure 33 Circuit diagram of the analogue output current test points

8.6. Adjusting the contrast of the display

The contrast of the display can be adjusted using the trimmer "LCD display contrast" located next to the press switches.

9. TECHNICAL DATA

9.1. Relative humidity

Measuring range 0...100 %RH

Accuracy (including nonlinearity and repeatability)

maximum achievable accuracy when calibrated against high quality, certified humidity standards:

±1 %RH (0...90 %RH)

±2 %RH (90...100 %RH)

when calibrated against salt solutions (ASTM E104-85):

±2 %RH (0...90 %RH)

±3 %RH (90...100 %RH)

Response time (90 %) at +20 °C in still air (with sintered filter) 15 s

Sensors

HUMICAP®K:

humidity sensor with blue dots on the sensor

HUMICAP®KC:

combined RH and T sensor (part no.18258HM)

9.2. Temperature

Measuring range

HMP231 -40...+60 °C

HMP233 -40...+80 / +120 °C

HMP234/235/237/238 -40...+180 °C

Typical accuracy of electronics at +20 °C (+68 °F) ±0.1 °C

Typical temperature dependence of electronics

0.005 °C/°C

Sensor

Pt 100 RTD 1/3 Class B IEC 751

9.3. Calculated variables

Typical ranges - HMP231

dewpoint temperature -40...+60 °C

mixing ratio 0...160 g/kg dry air

absolute humidity 0...160 g/m³

wet bulb temperature 0...+60 °C

enthalpy -40...+460 kJ/kg

Typical ranges - HMP233/234/235/237/238

dewpoint temperature	-40...+100 °C
mixing ratio	0...500 g/kg dry air
absolute humidity	0...600 g/m ³
wet bulb temperature	0...+100 °C
enthalpy	-40...+1500 kJ/kg

Accuracies of the calculated quantities depend on the accuracies of the measured quantities: relative humidity and temperature. In the tables below their accuracies are ± 2 %RH and ± 0.2 °C.

Accuracy of dewpoint temperature (°C)										
	Relative humidity									
Temp.	10	20	30	40	50	60	70	80	90	100
-40	1.86	1.03	0.76	0.63	0.55	0.50	0.46	0.43	-	-
-20	2.18	1.19	0.88	0.72	0.62	0.56	0.51	0.48	-	-
0	2.51	1.37	1.00	0.81	0.70	0.63	0.57	0.53	0.50	0.48
20	2.87	1.56	1.13	0.92	0.79	0.70	0.64	0.59	0.55	0.53
40	3.24	1.76	1.27	1.03	0.88	0.78	0.71	0.65	0.61	0.58
60	3.60	1.96	1.42	1.14	0.97	0.86	0.78	0.72	0.67	0.64
80	4.01	2.18	1.58	1.27	1.08	0.95	0.86	0.79	0.74	0.70
100	4.42	2.41	1.74	1.40	1.19	1.05	0.95	0.87	0.81	0.76
120	4.86	2.66	1.92	1.54	1.31	1.16	1.04	0.96	0.89	0.84
140	5.31	2.91	2.10	1.69	1.44	1.26	1.14	1.05	0.97	0.91
160	5.80	3.18	2.30	1.85	1.57	1.38	1.24	1.14	1.06	0.99

Accuracy of mixing ratio (g/kg) when ambient pressure is 1013 mbar										
	Relative humidity									
Temp.	10	20	30	40	50	60	70	80	90	100
-40	0.003	0.003	0.003	0.003	0.003	0.004	0.004	0.004	-	-
-20	0.017	0.018	0.019	0.021	0.022	0.023	0.025	0.026	-	-
0	0.08	0.09	0.09	0.10	0.10	0.11	0.11	0.12	0.13	0.13
20	0.31	0.33	0.35	0.37	0.39	0.41	0.43	0.45	0.47	0.49
40	0.97	1.03	1.10	1.17	1.24	1.31	1.38	1.46	1.54	1.62
60	2.68	2.91	3.16	3.43	3.72	4.04	4.38	4.75	5.15	5.58
80	6.73	7.73	8.92	10.34	12.05	14.14	16.71	19.92	24.01	29.29
100	16.26	21.34	28.89	40.75	60.86	98.85	183.66	438.56	-	-
120	40.83	74.66	172.36	-	-	-	-	-	-	-

Accuracy of absolute humidity (g/m³)										
	Relative humidity									
Temp.	10	20	30	40	50	60	70	80	90	100
-40	0.004	0.004	0.005	0.005	0.005	0.006	0.006	0.006	-	-
-20	0.023	0.025	0.027	0.029	0.031	0.032	0.034	0.036	-	-
0	0.10	0.11	0.12	0.13	0.13	0.14	0.15	0.15	0.16	0.17
20	0.37	0.39	0.41	0.43	0.45	0.47	0.49	0.51	0.53	0.55
40	1.08	1.13	1.18	1.24	1.29	1.34	1.39	1.44	1.49	1.54
60	2.73	2.84	2.95	3.07	3.18	3.29	3.40	3.52	3.63	3.74
80	6.08	6.30	6.51	6.73	6.95	7.17	7.39	7.61	7.83	8.05
100	12.2	12.6	13.0	13.4	13.8	14.2	14.6	15.0	15.3	15.7
120	22.6	23.3	23.9	24.6	25.2	25.8	26.5	27.1	27.8	28.4
140	39.1	40.0	41.0	42.0	43.0	44.0	45.0	45.9	46.9	47.9
160	63.5	64.9	66.4	67.8	69.2	70.7	72.1	73.5	74.9	76.4

Accuracy of wet bulb temperature (°C)										
	Relative humidity									
Temp.	10	20	30	40	50	60	70	80	90	100
-40	0.20	0.20	0.20	0.20	0.20	0.20	0.20	0.20	-	-
-20	0.21	0.21	0.22	0.22	0.22	0.22	0.23	0.23	-	-
0	0.27	0.28	0.28	0.29	0.29	0.29	0.30	0.30	0.31	0.31
20	0.45	0.45	0.45	0.44	0.44	0.44	0.43	0.43	0.42	0.42
40	0.84	0.77	0.72	0.67	0.64	0.61	0.58	0.56	0.54	0.52
60	1.45	1.20	1.03	0.91	0.83	0.76	0.71	0.67	0.63	0.60
80	2.23	1.64	1.32	1.13	0.99	0.89	0.82	0.76	0.72	0.68
100	3.06	2.04	1.58	1.31	1.14	1.01	0.92	0.85	0.80	0.75
120	3.85	2.40	1.81	1.48	1.28	1.13	1.03	0.95	0.88	0.83
140	4.57	2.73	2.03	1.65	1.41	1.25	1.13	1.04	0.97	0.91
160	5.25	3.06	2.25	1.82	1.55	1.37	1.24	1.13	1.05	0.99

Accuracy of enthalpy (kJ/kg) at ambient pressure 1013 mbar										
	Relative humidity									
Temp.	10	20	30	40	50	60	70	80	90	100
-40	0.21	0.21	0.21	0.21	0.21	0.21	0.21	0.21	-	-
-20	0.24	0.25	0.25	0.25	0.26	0.26	0.26	0.27	-	-
0	0.4	0.42	0.43	0.45	0.46	0.47	0.49	0.5	0.52	0.53
20	0.98	1.03	1.08	1.13	1.18	1.23	1.29	1.34	1.39	1.45
40	2.7	2.87	3.04	3.22	3.4	3.59	3.78	3.98	4.18	4.39
60	7.2	7.82	8.48	9.19	9.96	10.79	11.69	12.65	13.7	14.84
80	18.04	20.72	23.88	27.66	32.22	37.77	44.61	53.17	64.02	78.06
100	43.96	57.64	77.98	109.93	164.1	266.37	494.62	1180.46	-	-
120	111.6	203.93	470.52	-	-	-	-	-	-	-

The formulas used in calculation of dewpoint, mixing ratio, absolute humidity and enthalpy are presented in Appendix 6.

9.4. Pressure

Pressure range:

HMP234 0...10 MPa (0...100 bar)

HMP237 0...1MPa (0...10 bar)

HMP238 0...4 MPa (0...40 bar)

9.5. Analogue outputs

Two analogue outputs selectable 0...20 mA 4...20 mA
0...1 V 0...5 V
0...10 V

Typical accuracy of analogue output at +20 °C ±0.05 % full scale

Typical temperature dependence of analogue output 0.005 %/°C full scale

9.6. Electronics

User interface	3 keys and 4 LEDs inside the housing or local display keypad
Display	2 x 16 character alphanumeric high-contrast, wide view angle LCD
character height	3.85 mm (0.15")
Keyboard	1 x 4 keypad
Connections	screw terminals, 0.5 mm ² wires (AWG 20), stranded wires recommended
Operating voltage	24 VDC (20...28 V) 24 VAC (see page 23) 115/230 VAC with power supply module (not with the HMP231)
Power consumption: during re-gaining of the alarm output module	100 mA maximum (24 VDC) 180 mA maximum (24 VDC) 55 mA maximum (24 VDC)
Recommended external load for current outputs	<500
0...1 V voltage output	>2 k (to ground)
0...5 and 0...10 V voltage outputs	>10 k (to ground)
Operating temperature (electronics)	-40...+60 °C
with display cover	0...+50 °C
with power supply module	-40...+45 °C
with alarm outputs up to 8 A	-40...+40 °C
with alarm outputs up to 6 A	...+60 °C
Storage temperature	-40...+70 °C

9.7. Mechanics

Housing material	G-ALSi12 (DIN 1725)
Housing classification	IP 65 (NEMA 4)
Bushing	for 7...10 mm diameter cable (8 x 0.5 mm ² shielded cable)
Sensor protection	stainless steel sintered filter (part no. 16452) PPS grid with stainless steel netting (part no. 16720) PPS grid (part no. 16562)
Housing dimensions	145 x 120 x 65 mm
Sensor head dimensions	See figures 34 to 37.
HMP233 cable diameter	
+80 °C cable	6 mm
+120 °C cable	5.5 mm
HMP234/235/237/238 cable diameter	5.5 mm

Weight (without display cover and power supply module):

HMP231	970 g			
	with	2 m cable	5 m cable	
			10 m cable	
HMP233 (+ 80°C cable)		1100 g	1200 g	1450 g
HMP233 (+ 120°C cable)		1100 g	1300 g	1600 g
HMP234		1300 g	1600 g	2100 g
HMP235		1300 g	1600 g	2100 g
HMP238		1380 g	1550 g	1820 g

Weight of display cover	420 g
Weight of power supply module	240 g

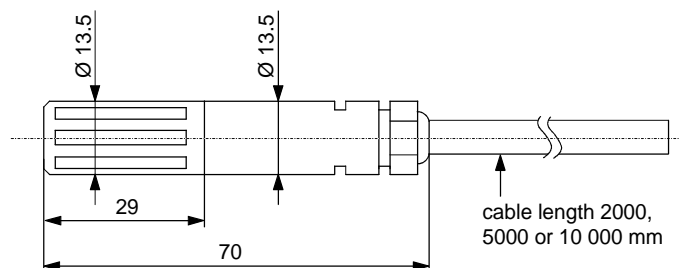

Figure 34 HMP233 sensor head dimensions

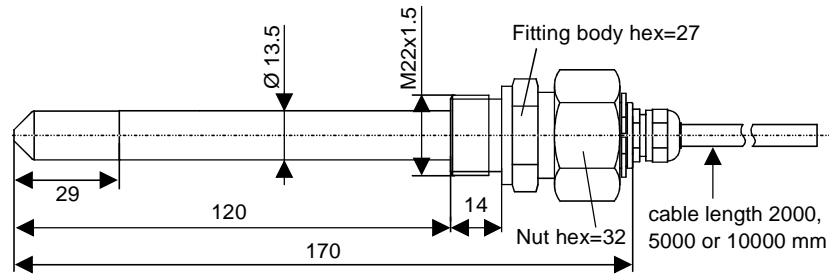

Figure 35 HMP234 sensor head dimensions

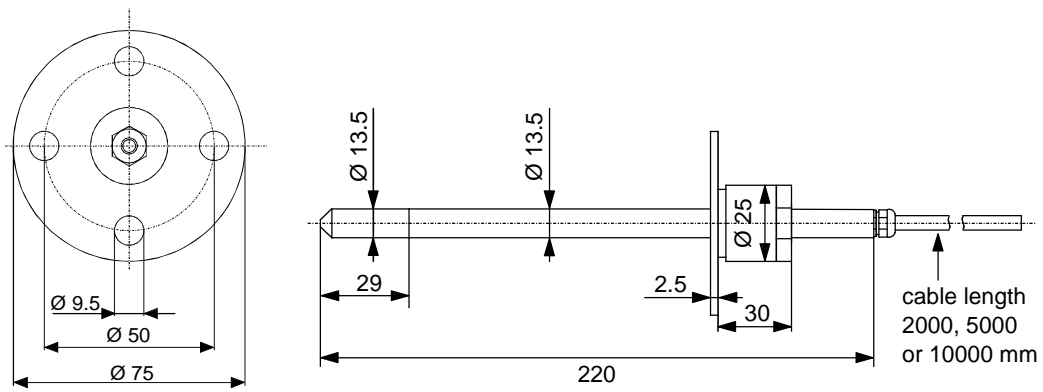

Figure 36 HMP235 sensor head dimensions

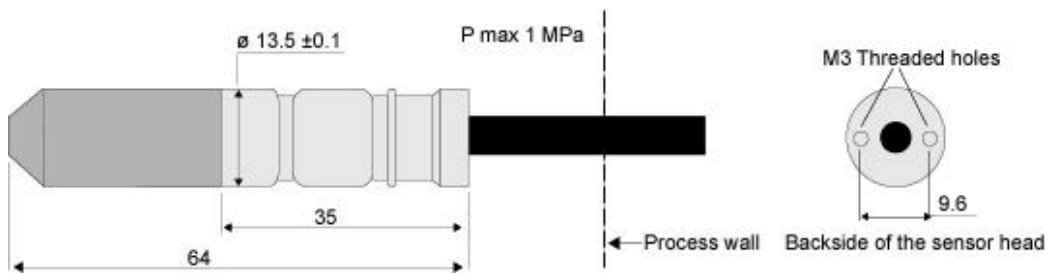

Figure 37 HMP237 sensor head dimensions.

HMP238 sensor head dimensions, see page 13.

9.8. Electromagnetic compatibility

HMP230 series transmitters fulfill the standard EN 61326-1:1997 +Am 1:1998, Electrical equipment for measurement, control and laboratory use - EMC requirements; Industrial environment (Generic environment for HMP233 with low temperature sensor cable).

Test methods

Emission

Radiated emissions CISPR16 class B (CISPR22 Class B)

Immunity

Electrostatic discharge (ESD)	EN/IEC 61000-4-2
EM field	EN/IEC 61000-4-3
	Industrial environment: 10 V/m
	Generic environment: 3 V/m
EFT Burst	EN/IEC 61000-4-4
Surge	EN/IEC 61000-4-5
Conducted RF	EN/IEC 61000-4-6

NOTE

These tests are valid with the following specified sensor protections only.

Type:	Sensor protection/notes:
HMP231	sintered filter (part no. 16452), PPS grid & stainless steel netting (part no. 16720)
HMP233	
high temperature (120 °C)	PPS grid & stainless steel netting (part no. 16720)
low temperature (80 °C)	sintered filter (part no. 16452) PPS grid & stainless steel netting (part no. 16720)
HMP234	sintered filter (part no. 16452)
HMP235	sintered filter (part no. 16452), PPS grid & stainless steel netting (part no. 16720)
HMP237	sintered filter (part no. 16452), PPS grid & stainless steel netting (part no. 16720)
HMP238	sintered filter (part no. 16452)

Voltage proof, AC: DC supply (+ or -) to housing 250 VAC, 1 minute (300 k and 15 nF parallel)



10. SPARE PARTS AND OPTIONS

Order code	Description
HMP235FS	Mounting flange for HMP235, stainless steel
HMP235FA	Mounting flange for HMP235, aluminium
HMP233FA	Mounting kit for HMP233, +80 °C cable
HMP233FAH	Mounting kit for HMP233, +120 °C cable
DMP248BVS	Ball valve set for HMP238
HMP243FA	Installation kit for duct mounting
16452	Sintered filter, stainless steel
16720	PPS grid with stainless steel netting
16562	PPS grid
HUMICAP®K	HUMICAP®K humidity sensor (blue dots on contacts)
HUMICAP®KC	Composite humidity and temperature sensor
HMK15	Humidity calibrator
HMK13B	Humidity calibrator
16611	Calibration adapter for the HMK13B
HMP230PW	Power supply module
HMP230RS	RS 485/422 serial module
HMP230CL	Current loop module
DMP240ALSP	Alarm output module
5237	Fuse 160 mA T 5x20 mm for power supply module
17223	Fitting body for HMP234 (standard)
17225	NTP conical pipe threaded fitting body for HMP234 (1/2 - 14 NPT)

11. FACTORY CALIBRATION AND REPAIR SERVICE

Vaisala SSD Service Centres

Vaisala SSD Service, Vanha Nurmijärventie 21 FIN-01670 Vantaa, FINLAND.
Phone: +358 9 8949 2758, Fax +358 9 8949 2295, ssdservice@vaisala.com

Vaisala KK, 42 Kagurazaka 6-Chome, Shinjuku-Ku, Tokyo 162-0825, JAPAN.
Phone: +81 3 3266 9611, Fax +81 3 3266 9610, aftersales.asia@vaisala.com

Vaisala Inc., 100 Commerce Way, Woburn, MA 01801-1068, USA.
Phone: +1 781 933 4500, Fax +1 781 933 8029, us-customersupport@vaisala.com

Internet: <http://www.vaisala.com>
Technical support: helpdesk@vaisala.com

SERIAL COMMANDS

1. ANALOGUE OUTPUT COMMANDS	81
AMODE Setting the analogue outputs.....	81
ASEL Scaling the analogue outputs	82
ASCL Scaling the analogue outputs	83
2. CALIBRATION COMMANDS	84
CRH Relative humidity calibration	84
FCRH Relative humidity calibration after sensor change.....	84
CT Temperature calibration	85
ACAL Calibrating the analogue outputs.....	86
L Outputting linear correction coefficients	86
LI Entering linear correction coefficients	86
3. OUTPUT VIA THE SERIAL BUS	87
R Starting the measurement output	87
S Stopping the measurement output	87
SEND Outputting a reading once	88
DSEND Outputting readings of all connected transmitters once	88
ERRS Outputting error messages.....	88
ECHO Turning the serial interface echo ON/OFF	89
INTV Setting the output interval for the RUN state	89
FORM Setting the output format.....	90
FTIME Adding time to output	91
FDATE Adding date to output.....	92
SERI Serial bus settings	92
UNIT Selecting the output units.....	93
ADDR Setting the transmitter address	94
FROST Setting the calculation mode	94
RESET Resetting the transmitter.....	94
3.1 Operation modes	95
SMODE Setting the serial interface	95
OPEN & CLOSE	95
4. OTHERS	97
ITEST Testing the analogue outputs	97
FILT Setting the averaging time	98
PRES Setting the pressure for pressure compensation of the HUMICAP® sensor and for mixing ratio, wet bulb temperature and enthalpy calculations	98
XPRES Setting the pressure for pressure compensation of the HUMICAP® sensor and mixing ratio, wet bulb temperature and enthalpy calculations temporarily.....	99
CDATE Entering calibration date	99
DATE Setting the date	100
TIME Setting the time.....	101
VERS Name and version of the programme	101
? Outputting the transmitter settings	101
?? Outputting the transmitter settings also in POLL mode.....	102

The commands function as described when the serial interface is in full-duplex mode and echo is on. All commands except FORM can be given in either capital or small letters. In the commands <cr> means carriage return, <lf> line feed and <ht> horizontal tabulation.

1. ANALOGUE OUTPUT COMMANDS

AMODE Setting the analogue outputs

Disconnect the security lock jumper!

AMODE a bb.bbb cc.ccc d ee.eee ff.fff <cr>

a = channel 1: U = voltage output
I = current output
bb.bbb = lower limit of channel 1
cc.ccc = upper limit of channel 1
d = channel 2: U = voltage output
I = current output
ee.eee = lower limit of channel 2
ff.fff = upper limit of channel 2

The bb.bbb, cc.ccc, ee.eee and ff.fff parameters are entered in volts or milliamperes.

Sets the analogue outputs on channels 1 and 2. An example: the voltage output on channel 1 is set to be 0...1 V and channel 2 set to 2...10 V:

```
>AMODE U 0 1 U 2 10 <cr>
Ch1 : 0.000 ... 1.000 V
Ch2 : 2.000 ... 10.000 V
```

The current settings can be checked by giving the command without any parameters:

```
>AMODE <cr>
Ch1 : 0.000 ... 20.000 mA
Ch2 : 0.000 ... 20.000 mA
```

ASEL Scaling the analogue outputs

Disconnect the security lock jumper!

ASEL xxx yyy <cr>

xxx = channel 1's quantity
yyy = channel 2's quantity:
 RH = relative humidity
 T = temperature
 Td = dewpoint temperature
 Abs = absolute humidity
 Mix = mixing ratio
 h = enthalpy
 Tw = wet bulb temperature

Example: relative humidity selected on channel 1 and temperature on channel 2

```
>ASEL RH T <cr>
Ch1 (RH) lo  0.000 %RH? <cr>
Ch1 (RH) hi  100.000 %RH  ? <cr>
Ch2 (T )   lo  -40.000 'C   ? <cr>
Ch2 (T )   hi  +160.000 'C   ? <cr>
```

When the ASEL command is given on its own, the transmitter outputs its current settings:

```
>ASEL <cr>
Ch1 (RH) lo  0.000 %RH
Ch1 (RH) hi  100.000 %RH
Ch2 (T ) lo  -40.000 'C
Ch2 (T ) hi  +160.000 'C
```

The outputs and their scales can also be given directly with the ASEL command.

ASEL xxx yyy aaa.a bbb.b ccc.c ddd.d <cr>

xxx = channel 1's quantity
yyy = channel 2's quantity
aaa.a = lower limit of channel 1
bbb.b = upper limit of channel 1
ccc.c = lower limit of channel 2
ddd.d = upper limit of channel 2

ASCL Scaling the analogue outputs**Disconnect the security lock jumper!****ASCL <cr>**

Scales the outputs selected on channels 1 and 2.

For example, scaling relative humidity on the range of 0...100 %RH and temperature -40...+160 °C:

```
>ASCL <cr>
Ch1 (RH) lo  0.000 %RH? <cr>
Ch1 (RH) hi  100.000 %RH  ? <cr>
Ch2 (T ) lo  0.000 'C ?  -40 <cr>
Ch2 (T ) hi  100.000 'C   ?  160 <cr>
```

The output scales can also be given directly with the ASCL command.

ASCL aaa.a bbb.b ccc.c ddd.d <cr>

```
aaa.a  =  lower limit of channel 1
bbb.b  =  upper limit of channel 1
ccc.c  =  lower limit of channel 2
ddd.d  =  upper limit of channel 2
```

For example, relative humidity is scaled to 0...100 %RH on channel 1 and temperature to -40...+100 °C on channel 2:

```
>ASCL 0 100 -40 100 <cr>
Ch1 (RH) lo  0.000 %RH
Ch1 (RH) hi  100.000 %RH
Ch2 (T ) lo  -40.000 'C
Ch2 (T ) hi  100.000 'C
```

2. CALIBRATION COMMANDS

CRH Relative humidity calibration

Disconnect the security lock jumper!

CRH <cr>

With this command the transmitters can be calibrated against a reference. A one-point calibration can be done against an accurate transfer standard in the field and a two-point calibration using saturated salt solutions in controlled conditions. A two-point calibration is performed as follows:

```
>CRH <cr>
RH : 12.00 Ref1 ? 11.3 <cr>
Press any key when ready ...
RH : 76.00 Ref2 ? 75.5 <cr>
```

In one-point offset correction, the Ref2 prompt is acknowledged with <cr>:

```
>CRH <cr>
RH : 12.80 Ref1 ? 11.3 <cr>
Press any key when ready ...
RH : 75.50 Ref2 ? <cr>
```

If the stabilization of the sensor to the humidity in the calibrator needs to be monitored, the measurement output can be repeated by giving command c<cr> at Ref1 and Ref2:

```
>CRH <cr>
RH : 12.00 Ref1 ? c <cr>
RH : 11.70 Ref1 ? c <cr>
RH : 11.50 Ref1 ? 11.3 <cr>
Press any key when ready ...
RH : 76.00 Ref2 ? 75.5 <cr>
```

FCRH Relative humidity calibration after sensor change

Disconnect the security lock jumper!

FCRH <cr>

After humidity sensor change the transmitter must be calibrated using this command and the calibration must be done at two reference points. The calibration is performed as follows:

```
>FCRH <cr>
RH : 1.90 Ref1 ? 11.3 <cr>
Press any key when ready ...
RH : 76.30 Ref2 ? 74.9 <cr>
```

The command can also be divided into two commands, so the computer can be used for other purposes while waiting for the sensor to stabilize to the higher humidity.

```
>FCRH 1 <cr>
RH : 1.90 Ref1 ? 11.3 <cr>

FCRH 2 <cr> ...
RH : 76.30 Ref2 ? 74.9 <cr>
```

If the stabilization of the sensor to the humidity in the calibrator needs to be monitored, the measurement output can be repeated by giving command c<cr> at Ref1 and Ref2:

```
>FCRH <cr>
RH : 12.00 Ref1 ? c <cr>
RH : 11.70 Ref1 ? c <cr>
RH : 11.50 Ref1 ? 11.3 <cr>
Press any key when ready ...
RH : 76.00 Ref2 ? 75.5 <cr>
```

CT Temperature calibration

Disconnect the security lock jumper!

CT <cr>

Using this command the transmitters can be calibrated against an accurate reference, such as a Pt 100 simulator. A two-point calibration is performed as follows:

```
>CT <cr>
T : 0.80 Ref1 ? 0.0 <cr>
Press any key when ready ...
T : 56.20 Ref2 ? 55.0 <cr>
```

In one-point offset correction, the Ref2 prompt is acknowledged with <cr>:

```
>CT <cr>
T : 0.80 Ref1 ? 0.0 <cr>
Press any key when ready ...
T : 75.50 Ref2 ? <cr>
```

If the stabilization of the sensor to the temperature of the calibrator or the reference needs to be monitored, the measurement output can be repeated by giving command c<cr> at Ref1 and Ref2:

```
>CT <cr>
T : 0.80 Ref1 ? c <cr>
T : 0.40 Ref1 ? 0.00 <cr>
Press any key when ready ...
T : 56.20 Ref2 ? 55.0 <cr>
```

ACAL Calibrating the analogue outputs

Disconnect the security lock jumper!

ACAL <cr>

Calibrates the outputs selected on channels 1 and 2. The output is measured and the measured values (mA or V) entered as calibration coefficients.

For example, calibrating the outputs when 0...10 V signal has been selected on both channels (set with AMODE command):

```
>ACAL <cr>
Ch1 U1 (V ) ? 0.123 <cr>
Ch1 U2 (V ) ? 9.98 <cr>
Ch2 U1 (V ) ? 0.120 <cr>
Ch2 U2 (V ) ? 9.98 <cr>
```

L Outputting linear correction coefficients

L <cr>

With the help of command L the user can check how the transmitter has been adjusted after it has been calibrated at the factory.

```
>L <cr>
RH offset : 0.000
RH gain : 1.000
Tsoffset : 0.000
Ts gain : 1.000
```

LI Entering linear correction coefficients

Disconnect the security lock jumper!

LI <cr>

The LI command is one way of calibrating the transmitters.

```
>LI <cr>
RH offset : 0.000 ? -.6 <cr>
RH gain : 1.000 ? <cr>
Ts offset : 0.000 ? <cr>
Ts gain : 1.000 ? .4 <cr>
```

The factory settings are offset 0 and gain 1. The transmitter can be returned to its factory calibration by giving these values.

NOTE

The temperature unit in offset correction is always degrees Centigrade, even if the transmitter is using non-metric units (Fahrenheit) in its measurement output.

3. OUTPUT VIA THE SERIAL BUS

R Starting the measurement output

R <cr>

Starts output of measurements to the peripheral devices (PC display or printer); output interval is set with command INTV.

The output format depends on the transmitter configuration and which variables are in use. The order, however, is always the same: relative humidity, temperature, dewpoint temperature, absolute humidity, mixing ratio and wet bulb temperature. An example:

```
RH= 43.0 %RH T= 21.0 'C Tdp= 8.0 'C x= 6.7 g/kg Tw= 13.7 'C  
h=34.4 kJ/kg <cr><lf>
```

When the transmitter sends out the readings, the serial interface does not echo any commands; the only command that can be used is S (stop).

The output mode can be changed with command FORM.

S Stopping the measurement output

S<cr>

Ends the RUN state; after this command all other commands can be used.

SEND Outputting a reading once

SEND <cr> in STOP state

or

SEND aa <cr> in POLL state

aa = address of the transmitter when more than one transmitter is connected to a serial bus (0...99; set with command ADDR)

Outputs the current measurement readings via the serial line. The output format depends on which parameters the transmitter can output. Output types are:

```
RH= 21.9 %RH T= 23.9 'C  
RH= 21.9 %RH T= 23.9 'C Td=0.9 'C  
RH= 21.9 %RH T=23.9 'C a=4.7 g/m3 x=4.0 g/kg Tw= 12.3 'C  
RH= 21.9 %RH T= 23.9 'C Td=0.9 'C a=4.8 g/m3 x=4.0 g/kg  
Tw=12.3 'C h=34.4 kJ/kg  
RH= 21.9 %RH T= 24.0 'C h= 34.4 kJ/kg
```

The output mode can be changed with command FORM.

DSEND Outputting readings of all connected transmitters once

DSEND <cr>

All transmitters connected to the serial bus send their addresses and current measurement readings in an order defined by their addresses. After receiving DSEND command a transmitter sets a delay time according to its address value and sends the data after this delay. DSEND works also in POLL mode. With this command the user can, for example, easily find out the addresses of the transmitters.

The output when four transmitters with addresses 4, 5, 10, 33 have been connected to the serial bus:

```
>dsend <cr>  
 4 14.43 %RH  
 5 22.7 'C  
10 14.99 %RH  
33 22.3 'C  
>
```

ERRS Outputting error messages

ERRS <cr>

During operation error messages are not output automatically through the serial interface. If there is any reason to doubt that there is something wrong with the transmitter, possible error messages can be output with command ERRS.

If there are no error messages, only a prompt is displayed:

```
>ERRS <cr>
>
```

If errors have occurred, the transmitter outputs the error code (see Appendix 5 for error messages):

```
>ERRS <cr>
E40 f ( all ) out of range
>
```

ECHO Turning the serial interface echo ON/OFF

ECHO xxx <cr>

xxx = ON or OFF

When the echo is off, the commands given through the serial interface or the prompt > cannot be seen on the display.

When the serial interface is in half-duplex mode, the echo is always off. Even then the ECHO command can indicate that echo is on.

INTV Setting the output interval for the RUN state

INTV xxx yyy <cr>

xxx = output interval (0...255)
0: no pause between outputs
yyy = unit (s, min or h)

Sets the output interval when the transmitter outputs measurement readings to a peripheral device.

For example, the currently valid settings are output with:

```
>INTV <cr>
Output intrv. : 0 min
```

When this is changed into 10 minutes, the command is:

```
>INTV 10 <cr>
Output intrv. : 10 min
```

The unit is changed into seconds with:

```
>INTV S <cr>
Output intrv. : 10 s
```

The change can also be done with one command:

```
>INTV 10 S <cr>
Output intrv. : 10 s
```

FORM Setting the output format

```
FORM <cr>
"xxx...xxx"
? zzz...zzz <cr>
```

```
xxx...xxx = old format
zzz...zzz = new format
```

The FORM command sets the format of the outputs generated in RUN state and by SEND command. Please note that **capital and small letters have different meanings**.

```
\UU..UU\ relative humidity
\TT..TT\ temperature
\DD..DD\ dewpoint temperature
\AA..AA\ absolute humidity
\XX..XX\ mixing ratio
\WW..WW\ wet bulb temperature
\HH..HH\ enthalpy
\uu..uu\ unit according to the preceding variable
\n line feed <lf>
\r carriage return <cr>
\t horizontal tabulation <ht> or <tab>
\\ \
```

For example:

<u>format</u>	<u>output</u>
\UUU.UU\ \+TT.TT\r	100.00 +99.99 <cr>
\TTT.T\ \uu\r\n	15.2 'C <cr><lf>
\UUU.U\ \uuu\+DD.D\ \uu\r	46.9 %RH +10.8 'C <cr>

Any text can be written in the command and it appears in the output. For example:

```
RH: \UUU.U\ T: \+TT.TT\r RH: 54.0 T: +25 <cr>
```

The format can be deleted by giving \ as a parameter:

```
>FORM \<cr> Note. only one space before \ and none after
or
```

```
>FORM <cr>
"xxx...xxx"
?\<cr>
```

An example of a format suitable for use in Microsoft Excel spreadsheets:

```
>FORM <cr>
"xxx...xxx"
?\UUU.U\t\TTT.T\t\DDD.D\t\AAA.A\t\XXX.X\t\WWW.W\r\n
<cr>
```

The output is then:

```
47.4<tab> 22.4 <tab> 10.6 <tab> 9.4 <tab> 8.0 <tab> 15.4
<cr><lf>
```

FTIME Adding time to output

FTIME xxx <cr>

xxx = ON or OFF

When FTIME is activated, the current time is output at the beginning of the output line. The time is set with command TIME. After RESET or power on the current time is 00:00:00.

Activating the time output

```
>ftime on
Form. time      :  ON
>intv 5 s
Output intrv.  :      5 s
>r
09:31:13 RH= 19.4 %RH T= 26.0 'C
09:31:18 RH= 19.4 %RH T= 26.0 'C
09:31:23 RH= 19.8 %RH T= 26.0 'C
09:31:28 RH= 19.6 %RH T= 26.0 'C
09:31:33 RH= 19.5 %RH T= 26.0 'C
09:31:38 RH= 19.5 %RH T= 26.0 'C
...
```

setting the output interval

Inactivating the time output

```
>ftime off
Form. time      :  OFF
>r
RH= 19.4 %RH T= 26.1 'C
RH= 19.8 %RH T= 26.1 'C
RH= 20.6 %RH T= 26.1 'C
RH= 20.5 %RH T= 26.1 'C
RH= 19.9 %RH T= 26.1 'C
RH= 19.6 %RH T= 26.1 'C
...
```

FDATE Adding date to output

FDATE xxx <cr>

xxx = ON or OFF

When FDATE is activated, the current date is output at the beginning of the output line. The time is set with command DATE. After RESET or power on the current date is 1991-01-01.

Activating the date output

```
>fdate on
Form. date      :  ON
>r
1995-03-10 RH= 21.1 %RH T= 26.0 'C
1995-03-10 RH= 21.3 %RH T= 26.0 'C
1995-03-10 RH= 23.1 %RH T= 26.0 'C
1995-03-10 RH= 22.2 %RH T= 26.0 'C
1995-03-10 RH= 20.6 %RH T= 26.0 'C
...
```

Inactivating the date output

```
>fdate off
Form. date      :  OFF
>r
RH= 20.2 %RH T= 26.0 'C
RH= 19.9 %RH T= 26.0 'C
RH= 19.8 %RH T= 26.0 'C
RH= 19.7 %RH T= 26.0 'C
RH= 19.7 %RH T= 26.0 'C
...
```

SERI Serial bus settings

SERI b p d s x <cr>

b = bauds (300, 600, 1200, 2400, 4800, 9600)
p = parity (n = none, e = even, o = odd)
d = data bits (7 or 8)
s = stop bits (1 or 2)
x = duplex (H = half, F = full)

Giving the command on its own outputs the current settings:

```
>SERI <cr>
4800 E 7 1 FDX
```

The settings can be changed one parameter at a time or all parameters at once:

```
>SERI O H <cr>          changing parity and duplex
4800 O 7 1 HDX

>SERI 600 N 8 1 F <cr>  changing all parameters
600 N 8 1 FDX
```

The processor does not allow the following combinations:

- no parity, 7 data bits, 1 stop bit: if this combination is given the HMP230 programme will change the number of stop bits to 2
- even or odd parity, 8 data bits, 2 stop bits: if this combination is given the programme changes the number of stop bits to 1

NOTE

The serial bus settings become effective only after reset.

When the half-duplex mode is set, it will automatically turn the echo off. Even then the ECHO command can indicate that echo is on.

UNIT Selecting the output units

UNIT x <cr>

x = m(etric units)
n(on-metric units)

quantity	metric	non-metric
RH = relative humidity	%RH	%RH
T = temperature	°C	°F
Td = dewpoint temperature	°C	°F
a = absolute humidity	g/m ³	gr/ft ³
x = mixing ratio	g/kg	gr/lb
h = enthalpy	kJ/kg	Btu/lb
Tw = wet bulb temperature	°C	°F

For example, the command for setting the non-metric units is:

```
>UNIT N <cr>
Output units : non metric
```

When the command is given with no parameters, the transmitter outputs the currently valid setting.

ADDR Setting the transmitter address

ADDR aa <cr>

aa = address (0...99)

The address is used when more than one transmitter is connected to one serial bus. The ADDR command makes it possible to communicate with one transmitter at a time in POLL state.

For example, transmitter is given address 99

```
>ADDR <cr>  
Address : 2 ? 99 <cr>
```

When asking the current address, no address number is given:

```
>ADDR <cr>  
Address : 2 ? <cr>
```

FROST Setting the calculation mode

Disconnect the security lock jumper!

FROST ON/OFF <cr>

This command is used to select whether the transmitter calculates the frostpoint or the dewpoint (default) reading at dewpoint temperatures below 0 °C. Select FROST ON for frostpoint and FROST OFF for dewpoint calculations. For example:

```
>Frost <cr>  
Frost : ON  
>Frost off  
Frost : OFF  
>Frost on  
Frost : on  
>
```

RESET Resetting the transmitter

RESET <cr>

Resets the transmitter. All settings that have been changed stay in the memory even after reset or power failure.

3.1 Operation modes

SMODE Setting the serial interface

SMODE xxxx<cr>

xxxx = STOP, RUN or POLL

In STOP mode: measurements output only by command, all commands can be used

In RUN mode: outputting automatically, only command S can be used

In POLL mode: measurements output only with command SEND. When in POLL mode, the output state is changed as follows:

**OPEN aa <cr>
SMODE xxxx<cr>**

aa = address of the transmitter

xxxx = STOP, RUN or POLL

The OPEN command sets the bus temporarily in STOP MODE so that the SMODE command can be given. For example:

```
>SMODE <cr>                which mode is in use at the moment
Serial mode      : STOP
>SMODE STOP <cr>          setting STOP mode
Serial mode      : STOP
```

OPEN & CLOSE

OPEN nn <cr>

nn = address of the transmitter (0...99)

CLOSE <cr>

In STOP mode: command OPEN has no effect, CLOSE sets the transmitter in POLL mode

In POLL mode: command OPEN sets the transmitter temporarily in STOP mode, command CLOSE returns the instrument to POLL mode

When more than one transmitter is connected to the same serial bus, the POLL mode makes it possible to communicate with the transmitters. For example, a relative humidity calibration is performed at transmitter 2 (<bel> = ASCII 7):

```
>OPEN 2 <cr>
<cr><lf> 'HMP nn line opened for operator commands'
<cr><lf><lf><bel>
>CRH <cr>
...
>CLOSE <cr>
<cr><lf> 'line closed' <cr><lf>
```

4. OTHERS

ITEST Testing the analogue outputs

```
ITEST <cr>
```

or

```
ITEST a b <cr>
```

a = current/voltage of channel 1
b = current/voltage of channel 2

The operation of the analogue outputs can be tested by forcing the outputs to given values which can then be measured with a current/voltage meter from the analogue outputs. The response to ITEST command gives six outputs/parameters. Only the first two are relevant; they show the channel current or voltage in mA or V. The other four figures contain information for service purposes only.

Examples:

- reading the channel outputs and parameters

```
>itest <cr>
 1.9438  2.3483  1.00694 10.64634  1.97374  2.17665
>
```

- forcing outputs 0.5 V and 4 V to channels 1 and 2

```
>itest 0.5 4 <cr>
 0.5000  4.0000  1.00694 10.62970  1.23336  3.01722
>
```

- releasing the forced control and reading the outputs

```
>itest <cr>
 1.9427  2.3392  1.00731 10.62428  1.97157  2.16978
>
```

FILT Setting the averaging time

Disconnect the security lock jumper!

FILT nnnn <cr>

nnnn = averaging time (0 - 1024 seconds)

This command is used to set and inspect the averaging time during which the individual measurement samples are integrated to get an averaged reading. The time can be set in seconds within the range of 0 - 1024 (0 = no averaging time).

For example:

```
>FILT <cr>
Filter (S):  0 ?  1024
>

>FILT 100 <cr>
Filter (S):  100
>
```

PRES Setting the pressure for pressure compensation of the HUMICAP[®] sensor and for mixing ratio, wet bulb temperature and enthalpy calculations

PRES pppp.pp <cr>

pppp.pp = pressure (hPa)

The atmospheric pressure has an effect on mixing ratio, wet bulb temperature and enthalpy. Therefore, accurate calculations can be achieved only when the ambient pressure is taken into consideration. The pressure is used for pressure compensation of the HUMICAP[®] sensor in order to ensure the best possible measurement accuracy. If the process pressure differs from normal ambient pressure, the value has to be entered in the transmitter memory when using the transmitters HMP234 or HMP238. The pressure to be entered is the absolute pressure in hPa (or mbar) (for pressure unit conversion, see Appendix 10).

NOTE

The pressure compensation takes place only with the security lock jumper connected. If the security lock jumper is not connected, the pressure compensation is performed with the value 1013.25 hPa.

When the command is given, the transmitter first gives the currently used pressure; after this a new value can be entered or the old one acknowledged:

```
>PRES <cr>
Pressure : 1013.25 ? 1000.00 <cr>
```

When the currently used pressure is known, a new pressure can also be entered directly:

```
>PRES 1010 <cr>
Pressure : 1010
```

NOTE

If the pressure setting is frequently adjusted, e.g. by using an external barometer as a pressure input source, the command XPRES is recommended.

XPRES Setting the pressure for pressure compensation of the HUMICAP[®] sensor and mixing ratio, wet bulb temperature and enthalpy calculations temporarily

```
XPRES pppp.pp <cr>
```

pppp.pp = pressure (hPa)

The function and format of XPRES are the same as those of the PRES command except that with XPRES command the setting is valid only until a reset is given, power is turned off or pressure is set to zero with XPRES. After this the pressure stored with command PRES is valid again.

CDATE Entering calibration date

```
CDATE xxxxxx <cr>
```

xxxxxx = calibration date (000101...991231)

When the latest calibration date has to be kept in memory, it is entered as follows:

```
>CDATE 940506 <cr>
```

If the command is given without the date, the transmitter outputs the latest calibration already in memory.

```
>CDATE <cr>
940420
```

The date can be given in any format; however, the maximum number of digits is six.

DATE Setting the date

DATE <cr>

For example, to enter a new date:

```
>DATE <cr>  
Current date is 1993-01-30  
Enter new date (yyyy-mm-dd) : 1993-06-12 <cr>
```

When the current date is asked, the new date is passed with <cr>.

TIME Setting the time

```
TIME <cr>
```

For example, to enter a new time:

```
>TIME <cr>
Current time is 01:35:54
Enter new time (hh:mm:ss) : 13:25:56 <cr>
```

When the current time is asked, the new time is passed with <cr>.

VERS Name and version of the programme

```
VERS <cr>
```

For example:

```
>VERS <cr>
HMP 230 / x.yy
```

where x.yy is the programme version.

? Outputting the transmitter settings

```
? <cr>
```

For example:

```
>? <cr>
HMP 230 / 3.01
CPU serial nr : S4330008
Keyboard type : 1
Address : 0
Output units : metric
Baud P D S : 4800 E 7 1 FDX
Serial mode : STOP
Output intrv. : 0 s
Mtim : 32
Pressure : 1013.25
Analog outputs
Ch1 0.00 ... 20.00 mA
Ch2 0.00 ... 20.00 mA
Ch1 ( RH ) lo 0.000 %RH
Ch1 ( RH ) hi 100.000 %RH
Ch2 ( T ) lo -40.000 'C
Ch2 ( T ) hi 180.000 'C
Transducer :
PRB serial nr : 9702
PRB cal. date : 970117
```

?? Outputting the transmitter settings also in POLL mode

?? <cr>

Command ?? outputs the same information as command ? but it works also when the transmitter has been set to POLL mode. However, if there are more than one addressed transmitters connected to the serial bus, they all will respond at the same time and the output on the screen will be chaotic.

INSTALLING THE POWER SUPPLY MODULE

The mains power connection may be connected to the power supply module only by an authorized electrician. A readily accessible disconnect device shall be incorporated in the fixed wiring (IEC 950).

1. Remove the plastic plug in the transmitter housing and replace it with the cable gland.
2. Fasten the power supply module to the bottom of the housing with four screws
3. Select the correct mains voltage with voltage selector switch (230/115).
4. Attach the grounding wire screw (M4) and washer to the protective ground terminal on the right-hand side of the module.
5. Attach the wires from the power supply module to the power terminal on the main board of the transmitter (see figure below).

When the power supply module is on, the power on LED is lit.

NOTE

The jumper in connector X3 has to be in position ON; otherwise no power is supplied to the transmitter.

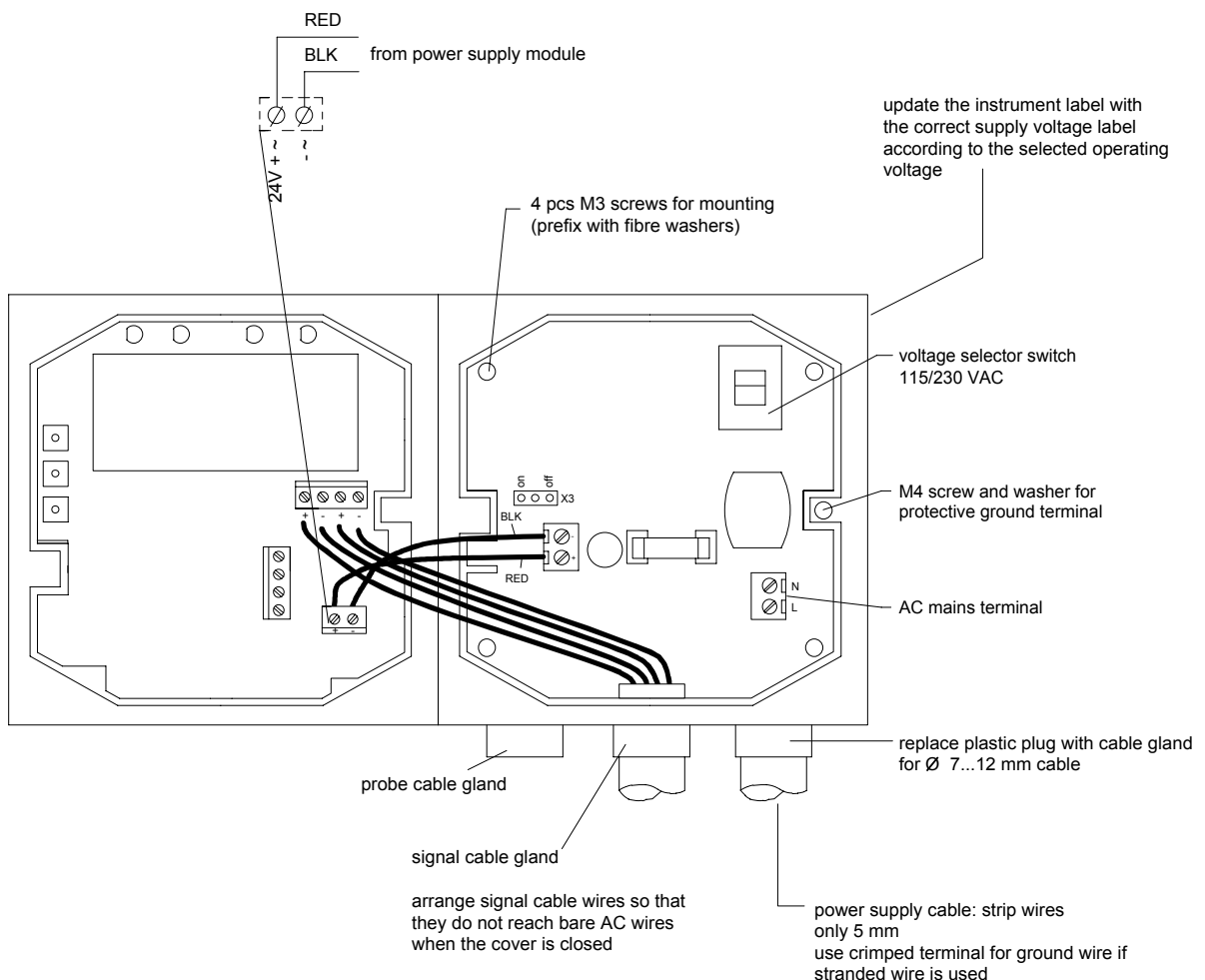

Peel the correct power supply voltage from the sticker enclosed in the power supply module package and attach it on the instrument label to indicate that the supply voltage has been changed.

NOTE 1 The power supply module is not recommended to be used in the HMP231 transmitters

NOTE 2 The power supply module cannot be used in transmitters with the re-gaining option.

WARNING Do not detach the power supply module from the transmitter when the power is on.

WARNING Do not connect the power supply to mains when it is not installed in a HMP230 transmitter.

WARNING Always connect protective ground terminal !

TECHNICAL SPECIFICATIONS

Operating voltage	115 VAC (93...127 V) 230 VAC (187...253 V)
Connections	screw terminals for 0.5... 2.5 mm ² wire (AWG 20...14)
Bushing	for 7...12 mm diameter cable
Indicator	PWR ON LED on power supply module board
Operating temperature range	-40...+45 °C
Storage temperature range	-40...+70 °C

INSTALLING AND USING THE RS 485/422 SERIAL PORT MODULE

1. INSTALLATION	107
2. OPERATION	108
3. NETWORK CONFIGURATION	110
Single loop operation.....	110
Dual loop operation.....	112
4. CHECKING THE SERIAL PORT NETWORK OPERATION	114
STOP mode	114
POLL mode	115
RS 485 network settings	115
5. SPECIFICATIONS	116

1. INSTALLATION

Switch the transmitter off.

Resistors R2, R3 and R4 between connectors X4 and X5 in the component board in the cover of the transmitter are removed with side-cutting pliers. The module is plugged in connectors X4 and X5 on the main board of the HMP230 transmitter; connector X1 on the module board to connector X4 and connector X2 to connector X5.

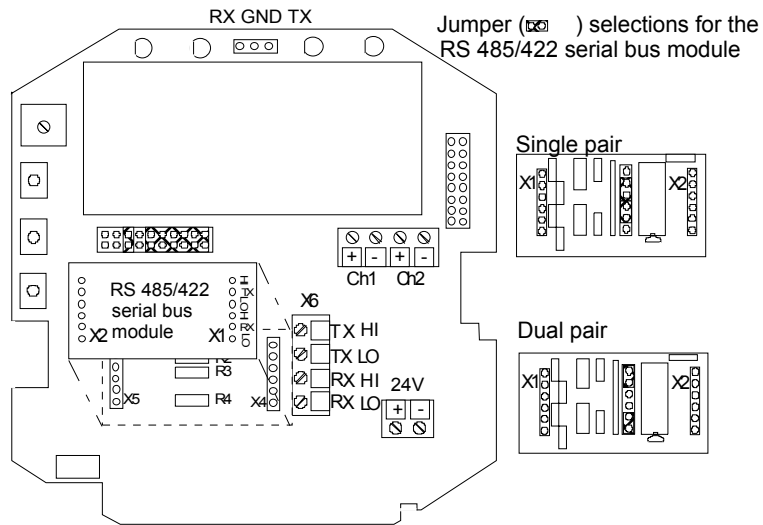

Cut off the resistors R2, R3 and R4 on the main board.
New signal names for X6 screw terminal are on the module.
Follow the instructions on the module:
X1 to X4 and
X2 to X5 on the mother board

NOTE! If the transmitter is NOT at the end of the bus OR the line has a dynamic line termination, the resistors R3 and R6 have to be removed!

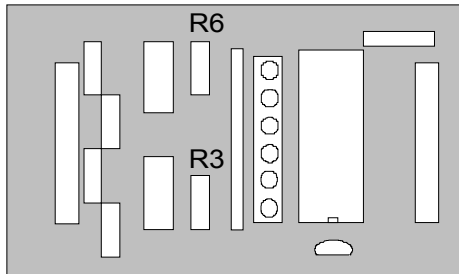

Connect the data wires to screw terminal X6 on the main board. Switch the power on.

2. OPERATION

The HMP230 transmitters can either be given an address or operated without an address. Both single and dual loop wiring with half duplex connection can be used. No address is needed when only one HMP230 transmitter is used; when several transmitters are connected to the same line, each transmitter must be given an address in the initial configuration.

A single transmitter can get its operating voltage from the master or it can have its own (floating) power supply or it has the power supply module in use.

The serial line structure is a parallel interfaced chain (daisy chain). At the ends of the serial line there must be a HMP230 transmitter, dynamic line adapter (120 ohm resistor in series with a 33 nF capacitor) or line master. If a branch line is made with a junction box, the branch should be shorter than 3 meters.

When connecting the device, follow the instructions given in the figure in Chapter 1.

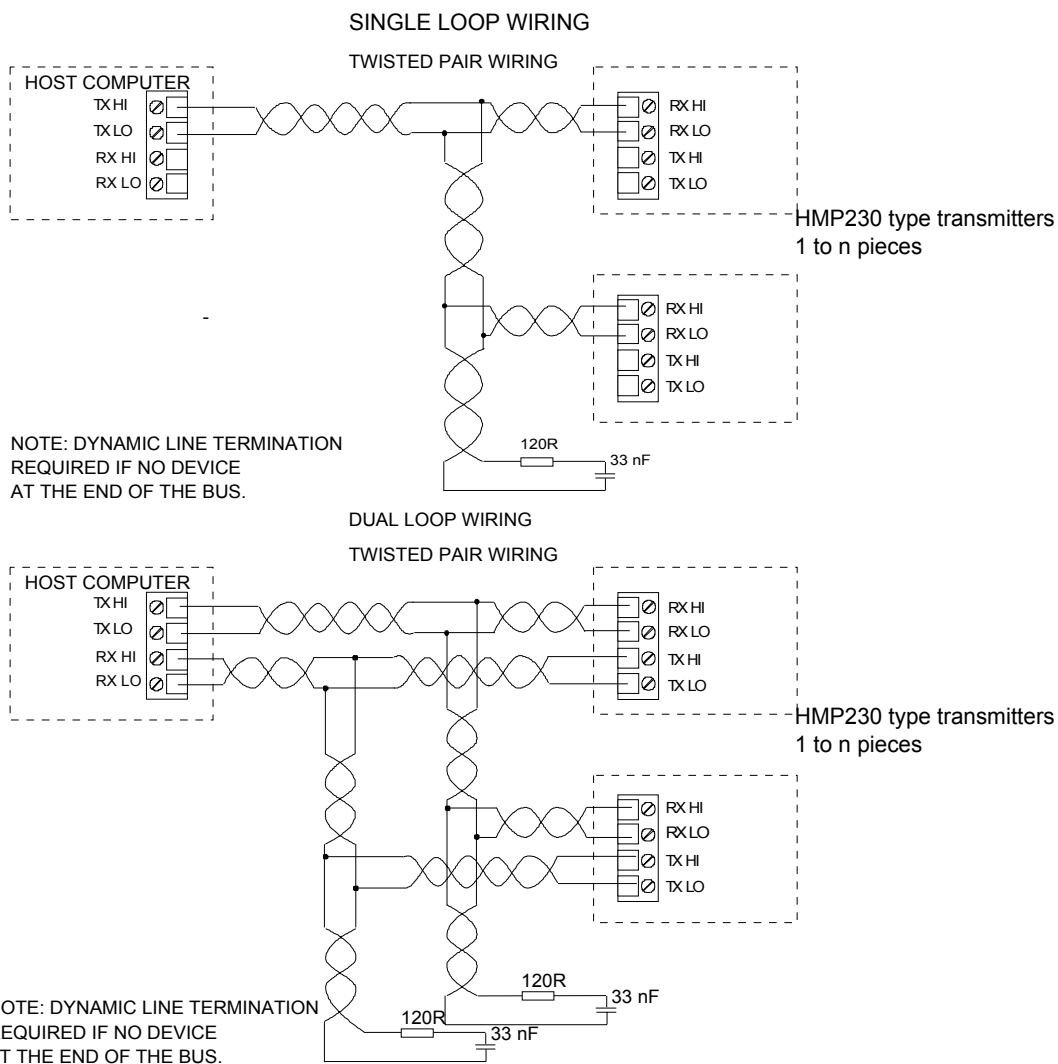

The RS 485/422 module has separate lines for transmitting and receiving, but they can be connected together with jumpers. Dual loop connection is the factory setting; when a single loop connection is used, the positions of jumpers in connector X4 on the module must be changed.

The HI of the receiving line is approx. 0.6 V and its LO is approx. 0 V in order to reduce noise on the lines when no data is transferred (idling). Both lines are terminated with a 120 ohm resistor in series with a 33 nF capacitor. When operating the transmitter through a single pair, naturally only one line terminal impedance is in use. The line must not be terminated with a resistor alone, as then the power consumption increases too much.

The data lines can withstand short circuit to ground and to each other. They do not survive connection of supply voltage to the data lines.

The module must be mounted on the main board in the right direction. It can be mounted in the wrong direction or to the wrong pins without breaking the module; it simply does not work then.

3. NETWORK CONFIGURATION

Single loop operation

Bi-directional data on one pair is one of the great advantages of the RS 485 line. Set jumpers in connector X4 on the module board as shown in the figure below.

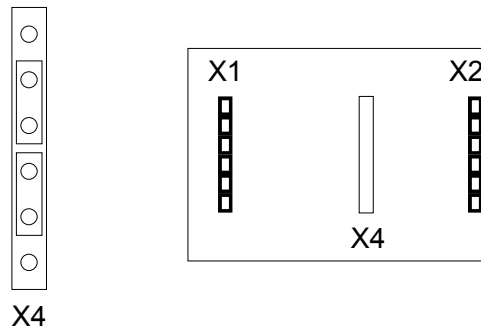

This jumper setting connects RX HI to TX HI and RX LO to TX LO and selects only one common line termination. The HI and LO terminals of the RX pair can now be used for operation.

Supplying power from the same end to the whole network prevents common mode voltages from rising too high (over 7 V).

- Connect wires to the transmitter's serial connector.
- Check the wiring.

The following procedure must be repeated with all transmitters.

- Open the transmitter cover.
- Pull out the RS 485/422 serial port module, if it is already mounted.
- Set the serial port of the terminal to 4800 baud, even parity, seven data bits and one stop bit, full duplex (4800 E 7 1 FDX).

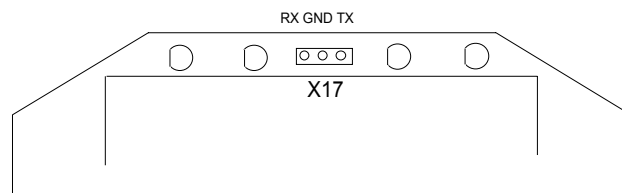

- The serial settings of the transmitter must also be 4800 E 7 1 FDX and the transmitter must be in STOP mode. If these factory settings have been changed, they must be changed back. Connect the RS 232C port of the terminal to connector X17 on the top of the main board and switch the power on.

- Set the address of the transmitter; it can be any number between 1 and 99. In this example the address is 22:

```
>addr 22
Address   : 22
```

- Set the serial bus settings according to your network specifications. This setting will become valid after next RESET or power off:

```
>seri 2400 e 7 1 h
2400 E 7 1 HDX
```

- Set the transmitter in POLL mode:

```
>smode poll
Serial mode : POLL
```

NOTE 1

The SMODE command must be given last.

NOTE 2

The transmitter outputs no prompt (>) after the SMODE POLL command and it only reacts to commands which include its address.

- Check that the transmitter responds to its address:

```
>send 22
RH= 24.4 %RH T= 29.1 'C
```

- Disconnect the terminal.
- Check that the jumpers in connector X4 are in the correct places.

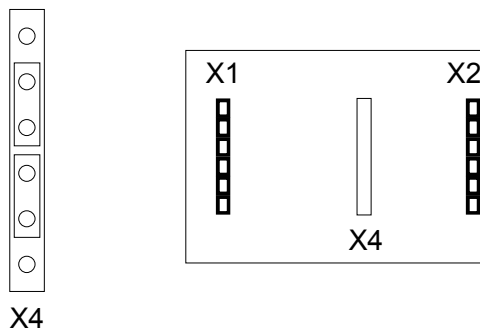

- Remount the RS 485/422 serial module.
- Close the cover.
- When all transmitters on the network have been configured, switch them off.

Dual loop operation

The following procedure must be repeated with all transmitters.

- Open the transmitter cover.
- Pull out the RS 485/422 serial port module, if it is already mounted.
- Set the serial port of the terminal to 4800 baud, even parity, seven data bits and one stop bit, full duplex (4800 E 7 1 FDX).
- The serial settings of the transmitter must also be 4800 E 7 1 FDX and the transmitter must be in STOP mode. If these factory settings have been changed, they must be returned. Connect the RS 232C port of the terminal to connector X17 on the top of the main board and switch the power on.

When dual loop is used, the jumpers in connector X4 on the module board must be as shown below.

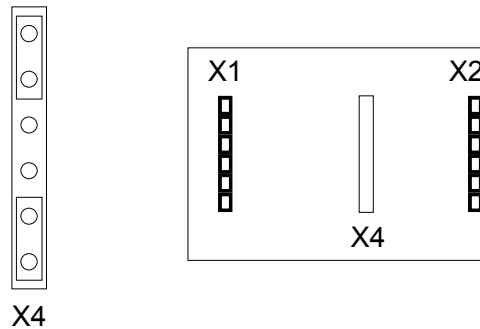

- Set the address of the transmitter, it can be any number between 1 and 99. In this example the address is 22:

```
>addr 22  
Address : 22
```

- Set the serial bus settings according to your system. This setting will become valid after next RESET or power off:

```
>seri 2400 e 7 1 f  
2400 E 7 1 FDX
```

- Switch echo on:

```
>echo on  
ECHO : ON  
>
```

- Change the serial output mode into POLL:

```
>smode poll  
Serial mode : POLL
```

NOTE 1

The SMODE command must be given last.

NOTE 2

The transmitter outputs no prompt (>) after the SMODE POLL command and it only reacts to commands which include its address.

- Check that the transmitter responds to its address:

```
>send 22  
RH= 24.4 %RH T= 29.1 'C
```

- Disconnect the terminal.
- Check that the jumpers in connector X4 are in the correct places:

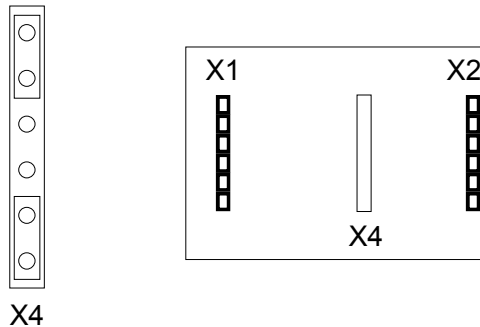

- Remount the RS 485/422 serial module.
- Close the cover.
- Repeat this setting procedure with each transmitter.
- When all transmitters on the network have been configured, switch them off.

4. CHECKING THE SERIAL PORT NETWORK OPERATION

Normally measurement readings are asked when the transmitter is in POLL mode; then the command must include the address of the transmitter. If the settings need to be changed, the transmitter is switched to STOP mode with command OPEN; commands can then be given without address. When the line to the transmitter is closed, it returns to POLL mode.

STOP mode

Open the line to the transmitter:

```
open 22<cr>
HMP 22 line opened for operator commands
```

Transmitter no. 22 is now temporarily set to STOP mode; it accepts commands sent without address until CLOSE command is given. Individual settings can now be easily modified. Do not open more than one line at a time.

Use command ? to find out the settings of the active transmitter:

```
>? <cr>
HMP 230 / 3.01
CPU serial nr      : S4330008
Keyboard type     : 1
Address           : 0
Output units      : metric
Baud P D S       : 4800 E 7 1 FDX
Serial mode       : STOP
Output intrv.    : 0 s
Mtim              : 32
Pressure          : 1013.25
Analog outputs
Ch1  0.00 ... 20.00 mA
Ch2  0.00 ... 20.00 mA
Ch1  ( RH )   lo  0.000 %RH
Ch1  ( RH )   hi 100.000 %RH
Ch2  ( T )   lo -40.000 'C
Ch2  ( T )   hi 180.000 'C
Transducer       :
PRB serial nr    : 9702
PRB cal. date    : 970117
```

When the necessary settings have been made, close the line to transmitters (the command closes all open lines):

```
>close
line closed
```

CLOSE command is always given without address. If no line is open, there will be no response to the CLOSE commands.

POLL mode

If a transmitter has been set to POLL mode, it will respond only to commands sent with its address:

```
send 22
RH= 24.4 %RH T= 29.1 'C
```

Addresses from 1 to 99 can be used. According to the RS 485/422 standard a maximum of 32 devices can be connected on same bus, but the number can be increased if the line length and/or baud rate is reduced.

More than one baud rate can be used on an RS 485 line. E.g. the host of the line can use different baud rates with different devices (this makes it possible to use the same address for several devices).

The line terminations must be dynamic; e.g. an RC circuit is used instead of a simple resistor termination. Each RS 485 module has a dynamic line termination so it can be used at the end of a line.

RS 485 network settings

HMP230 settings	single pair	dual pair
Full duplex/half duplex	HDX	FDX
Echo on/off	OFF	ON
Terminal settings		
	single pair	dual pair
Line feed after carriage re- turn	yes	no
HDX/FDX	FDX	FDX

When terminal is set to general <lf> (line feed) after <cr> (carriage return), the listings will have two line feeds if also the HMP230 transmitters send line feed.

5. SPECIFICATIONS

Connections on the main board	Berg sockets screw terminals 0.5 mm ² wires, stranded wires recommended
Assembly	plug-in module
Board dimensions	40 x 28 mm
Operating mode (single or dual pair wiring)	half duplex
Network:	
network type	daisy chain
cable type	twisted pair
line length max.	1000 m (3000 ft)
number of devices	32 devices on line
data speed	9600 baud max. for HMP230 transmitters
operating mode	polling mode
common mode voltage range	±7 V
Operating temperature	-40...+60 °C
Storage temperature	-40...+70 °C

INSTALLING AND USING THE DIGITAL CURRENT LOOP MODULE

1. INSTALLATION.....	118
2. OPERATION.....	119
3. NETWORK CONFIGURATION	121
Single loop operation	121
Single loop wiring.....	121
Dual loop operation	122
Dual loop wiring.....	123
4. CHECKING THE SERIAL PORT NETWORK OPERATION	124
STOP mode	124
POLL mode.....	125
Current loop settings.....	125
5. SPECIFICATIONS	126

1. INSTALLATION

Switch the transmitter off.

Resistors R2, R3 and R4 between connectors X4 and X5 in the component board in the cover of the transmitter are removed with side-cutting pliers. The module is plugged in connectors X4 and X5 on the main board of the HMP230 transmitter; connector X1 on the module board to connector X4 and connector X2 to connector X5.

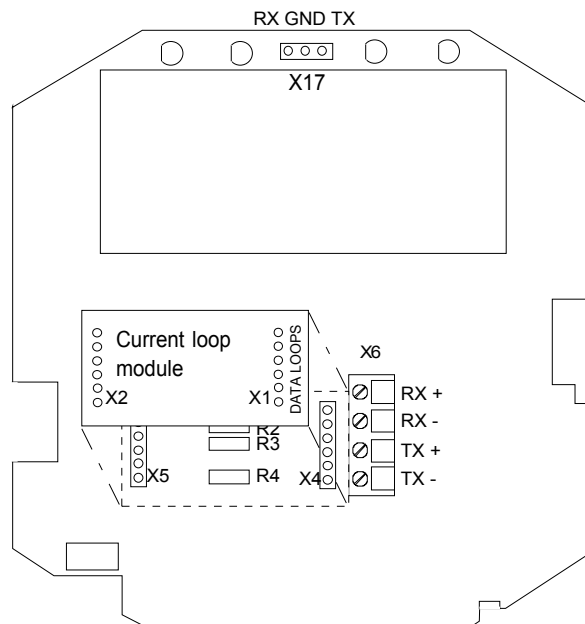

Connect the data wires to screw terminal X6 on the main board. Switch the power on.

2. OPERATION

The HMP230 transmitters can either be given an address or operated without an address. Both single and dual loop wiring with half duplex connection can be used. No address is needed when only one HMP230 transmitter is used; when several transmitters are connected to the same line, each transmitter must be given an address in the initial configuration.

A current loop must get its operating voltage from the master or it can have its own (floating) power supply capable of supplying 15...40 V and 20...30 mA. Unregulated AC/DC adapter can be used, if the current is limited to 20 mA at least by a serial resistor.

NOTE: The host computer can restrict the loop supply voltage that can be used; see computer specifications.

The serial line structure is a serial interfaced chain (daisy chain). At one end of the serial line there must be an HMP230 transmitter and at the other end a line master. A branch line can be made with a junction box.

SINGLE LOOP WIRING

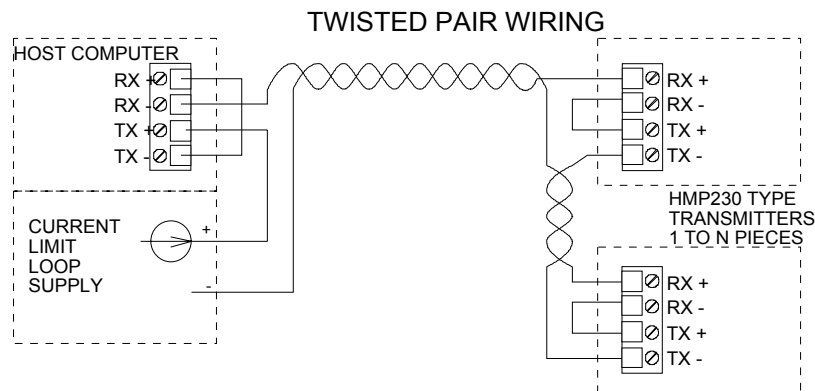

DUAL LOOP WIRING

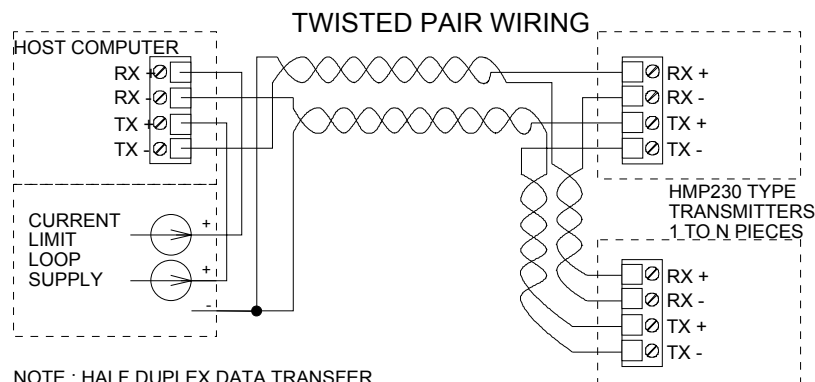

NOTE : HALF DUPLEX DATA TRANSFER.
HMP230 DOES NOT RECEIVE WHILE
TRANSMITTING VIA SERIAL PORT MODULE

The digital current loop module has separate lines for transmitting and receiving. Both single loop wiring and dual loop wiring can be used (see figure). With dual loop connection, it is possible to have a few more transmitters on the same loop pair. A single loop connection has simpler wiring. Data transmission is achieved by switching the loop current on and off.

Normally current flows through the loop(s) even when the HMP230 transmitter is not on, so switching one transmitter off does not affect the other transmitters on the loop.

When the wires have been connected correctly, the voltage drop from RX+ to RX- is below 2 V. If the wires RX+ and RX- or TX+ and TX- are connected incorrectly, the voltage drop from RX+ to RX- or from TX+ to TX- is below 1 V and the transmitter does not work. Even then the current goes through the loop and the other transmitters can be operated normally.

When the loop supply is current limited, the data lines can withstand short circuit to ground and to each other. They do not survive connection of supply voltage to the data lines.

The module must be mounted on the main board in the right direction. It can be mounted in the wrong direction or to the wrong pins without breaking the module; it simply does not work then. Reverse wiring of RX+ and RX- or TX+ and TX- does not affect the module.

3. NETWORK CONFIGURATION

Single loop operation

Bi-directional data on one pair and galvanic isolation are the advantages of the current loop. Single pair/dual pair use is configured through wiring (see figure on page 3).

Supplying power from the same end to the loops prevents crossover voltages.

- Connect wires to the transmitter's serial connector.
- Check the wiring.

The following procedure must be repeated with all transmitters.

- Open the transmitter cover.
- Pull out the digital current loop module, if it is already mounted.
- Set the serial port of the terminal to 4800 baud, even parity, seven data bits and one stop bit, full duplex (4800 E 7 1 FDX).
- The serial settings of the transmitter must also be 4800 E 7 1 FDX and the transmitter must be in STOP mode. If these factory settings have been changed, they must be returned. Connect the RS 232C port of the terminal to connector X17 on the top of the main board and switch the power on.

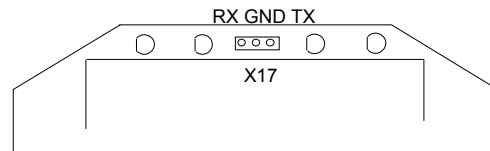

Single loop wiring

- Set the address of the transmitter; it can be any number between 1 and 99. In this example the address is 22:

```
>addr 22
Address : 22
```

- Set the serial bus settings according to your network specifications. This setting will become valid after next RESET or power off:

```
>seri 2400 e 7 1 h
2400 E 7 1 HDX
```

- Set the transmitter in POLL mode:

```
>smode poll  
Serial mode : POLL
```

NOTE 1

The SMODE command must be given last.

NOTE 2

The transmitter outputs no prompt (>) after the SMODE POLL command and it only reacts to commands which include its address.

- Check that the transmitter responds to its address:

```
send 22  
RH= 24.4 %RH T= 29.1 'C
```

- Disconnect the terminal.
- Remount the digital current loop module.
- Close the cover.
- When all transmitters on the network have been configured, switch them off.

Dual loop operation

Single pair/dual pair use is configured through wiring (see figure on page 2).

The following procedure must be repeated with all transmitters.

- Open the transmitter cover.
- Pull out the digital current loop module, if it is already mounted.
- Set the serial port of the terminal to 4800 baud, even parity, seven data bits and one stop bit, full duplex (4800 E 7 1 FDX).
- The serial settings of the transmitter must also be 4800 E 7 1 FDX and the transmitter must be in STOP mode. If these factory settings have been changed, they must be returned. Connect the RS 232C port of the terminal to connector X17 on the top of the main board and switch the power on.

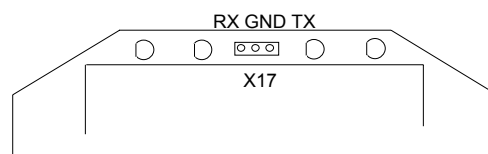

Dual loop wiring

- Set the address of the transmitter, it can be any number between 1 and 99. In this example the address is 22:

```
>addr 22
Address   : 22
```

- Set the serial bus settings according to your system. This setting will become valid after next RESET or power off:

```
>seri 2400 e 7 1 f
2400 E 7 1 FDX
```

- Switch echo on:

```
>echo on
ECHO    : ON
>
```

- Change the serial output mode into POLL:

```
>smode poll
Serial mode : POLL
```

NOTE 1

The SMODE command must be given last.

NOTE 2

The transmitter outputs no prompt (>) after the SMODE POLL command and it only reacts to commands which include its address.

- Check that the transmitter responds to its address:

```
>send 22
RH= 24.4 %RH T= 29.1 'C
```

- Disconnect the terminal.
- Remount the digital current loop module.
- Close the cover.
- Repeat this setting procedure with each transmitter.
- When all transmitters on the network have been configured, switch them off.

4. CHECKING THE SERIAL PORT NETWORK OPERATION

Normally measurement readings are asked when the transmitter is in POLL mode; then the command must include the address of the transmitter. If the settings need to be changed, the transmitter is switched to STOP mode with command OPEN; commands can then be given without address. When the line to the transmitter is closed, it returns to POLL mode.

STOP mode

Open the line to the transmitter:

```
open 22<cr>
HMP 22 line opened for operator commands
```

Transmitter no. 22 is now temporarily set to STOP mode; it accepts commands without address until CLOSE command is given. Individual settings can now be easily modified. Do not open more than one line at a time.

Use command ? to find out the settings of the active transmitter:

```
>? <cr>
HMP 230 / 3.01
CPU serial nr : S4330008
Keyboard type : 1
Address : 0
Output units : metric
Baud P D S : 4800 E 7 1 FDX
Serial mode : STOP
Output intrv. : 0 s
Mtim : 32
Pressure : 1013.25
Analog outputs
Ch1 0.00 ... 20.00 mA
Ch2 0.00 ... 20.00 mA
Ch1 ( RH ) lo 0.000 %RH
Ch1 ( RH ) hi 100.000 %RH
Ch2 ( T ) lo -40.000 'C
Ch2 ( T ) hi 180.000 'C
Transducer :
PRB serial nr : 9702
PRB cal. date : 970117
```

When the necessary settings have been made, close the line to transmitters (the command closes all open lines):

```
>close
line closed
```

CLOSE command is always given without address. If no line is open, there will be no response to the CLOSE commands.

POLL mode

If a transmitter has been set to POLL mode, it will respond only to commands sent with its address:

```
send 22
RH= 24.4 %RH T= 29.1 'C
```

Addresses from 1 to 99 can be used. According to the 20 mA current loop standard current flows with no transmission on line. A maximum of 6 devices can be connected on same single loop line, but the number can be increased to 9 by using dual loop wiring.

More than one baud rate can be used on a current loop line. E.g. the host of the line can use different baud rates with different devices (this makes it possible to use the same address for several devices).

Current loop settings

HMP230 settings	single pair	dual pair
Full duplex/half duplex	HDX	FDX
Echo on/off	OFF	ON
Terminal settings		
	single pair	dual pair
Line feed after carriage return	yes	no
HDX/FDX	FDX	FDX

When terminal is set to general <lf> (line feed) after <cr> (carriage return), the listings will have two line feeds if also the HMP230 transmitters send line feed.

5. SPECIFICATIONS

Galvanic isolation	1500 VAC/DC max. (1 min)
Loop supply voltage	40 V max.
Loop supply current must be current limited	20 mA nominal
Operating loop voltage requirement	4 V/each transmitter (TX+/TX-) on the loop 2 V/each receiver (RX+/RX-) on the loop
Loop current	12...30 mA (space) 0...2 mA (mark) 30 mA max.
Connections on the main board	Berg sockets screw terminals 0.5 mm ² wires, stranded wires recommended
Assembly	plug-in module
Board dimensions	40 x 28 mm
Operating mode (single or dual pair wiring)	half duplex
Network:	
network type	serial daisy chain
cable type	twisted pair
line length max.	1000 m (3000 ft)
number of devices	6 devices on line (single loop) 9 devices on line (dual loop)
data speed	4800 baud max.
operating mode	polling mode
isolation voltage proof	250 VAC (1 min)
Operating temperature	-40...+60 °C
Storage temperature	-40...+70 °C

ERROR MESSAGES

1. ERROR TYPES	128
1.1 Errors after reset	128
1.2 Errors during operation	130

1. ERROR TYPES

The HMP230 transmitters go through a self-diagnostics procedure when the power is switched on. When the procedure does not reveal any errors or faults, the transmitter starts operating normally. If errors or faults are found, the transmitter outputs an error message. Possible errors can also be checked with command ERRS (see Appendix 1). The error messages can be divided into two groups: error messages after reset and error messages during operation. Note also that if the analogue current output is selected to be 4 - 20 mA, in case of error the signal drops to 0 mA.

LED symbols:

○	LED dark
⊙	LED blinking
●	LED lit

1.1 Errors after reset

Display

Serial bus

```
E11 CPU EEPROM  
ackn. error
```

E11 CPU EEPROM ackn. error

- the CPU hybrid is probably damaged. Send the transmitter to Vaisala for repair.

```
E12 CPU EEPROM  
csun error
```

E12 CPU EEPROM checksum error

- possibly due to an electrical disturbance an erroneous parameter value or an incorrect checksum has been stored in the EEPROM. Change any parameter value (e.g. with command INTV) and give command RESET, or turn the power off and then on again. If the error message no longer appears, the transmitter is in order. Should the message re-appear repeatedly, send the transmitter to Vaisala for repair.

```

E21 PRB EEPROM
ackn. error

```

E21 PRB EEPROM ackn. error

- no connection to the EEPROM including calibration information can be formed. Send the transmitter to Vaisala for repair.

```

E22 PRB EEPROM
csun error

```

E22 PRB EEPROM checksum error

ackn. error = EEPROM is faulty
checksum error = check sum is erroneous

- possibly due to an electrical disturbance an erroneous calibration parameter value or an incorrect checksum has been stored in the EEPROM including the calibration information. Change any parameter value, e.g. RH offset: check the value with command L, write it down and then change it with command LI. Return the previous value with command LI and give command RESET, or turn the power off and then on again. If the error message no longer appears, check the transmitter reading and if it seems to be in order, the transmitter can be taken into use again. Should the message re-appear repeatedly, send the transmitter to Vaisala for repair.

The LEDs display these error types as follows:

○●○○	CPU EEPROM error
●○○○	input hybrid error

1.2 Errors during operation

Two types of errors are possible during operation of the transmitters. The first type indicates that no frequency comes from the converter.

Display:

Serial bus:

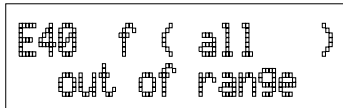

E40 f (all)
out of range

E40 f (all) out of range

- the measurement hybrid is probably damaged. Send the transmitter to Vaisala for repair.

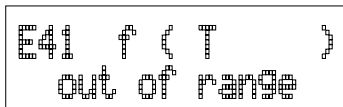

E41 f (T)
out of range

E41 f (T) out of range

- the temperature measurement cannot be completed. Check the temperature sensor and its solderings. Check the temperature measurement wires and their solderings on the component board (TP5,TP6,TP7 and TP8). If you cannot find any faults, send the transmitter to Vaisala for repair.

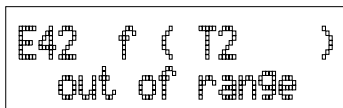

E42 f (T2)
out of range

E42 f (T2) out of range

- the temperature measurement cannot be completed. Check the temperature sensor and its solderings. Check the temperature measurement wires and their solderings on the component board (TP5,TP6,TP7 and TP8). If you cannot find any faults, send the transmitter to Vaisala for repair.

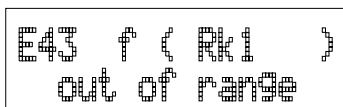

E43 f (Rk1)
out of range

E43 f (Rk1) out of range

- the temperature measurement cannot be completed. Check the temperature sensor and its solderings. Check the temperature measurement wires and their solderings on the component board (TP5,TP6,TP7 and TP8). If you cannot find any faults, send the transmitter to Vaisala for repair.

```
E44 f ( Rk2 )
out of range
```

E44 f (Rk2) out of range

- the temperature measurement cannot be completed. Check the temperature sensor and its solderings. Check the temperature measurement wires and their solderings on the component board (TP5,TP6,TP7 and TP8). If you cannot find any faults, send the transmitter to Vaisala for repair.

```
E45 f ( Ud1 )
out of range
```

E45 f (Ud1) out of range

- the humidity measurement cannot be completed. Check the HUMICAP sensor and humidity measurement wires and their solderings on the component board (TP9,TP10 and TP11/15). If you cannot find any faults, send the transmitter to Vaisala for repair.

```
E46 f ( Ud2 )
out of range
```

E46 f (Ud2) out of range

- the measurement hybrid is probably damaged. Send the transmitter to Vaisala for repair.

```
E47 f ( Uk1 )
out of range
```

E47 f (Uk1) out of range

- the measurement hybrid is probably damaged. Send the transmitter to Vaisala for repair.

```
E48 f ( Uk2 )
out of range
```

E48 f (Uk2) out of range

- the measurement hybrid is probably damaged. Send the transmitter to Vaisala for repair.

The LEDs display these error types as follows:

○○⚙⚙	no frequency at all
○○⚙○	a frequency missing from the RH channel
○○○⚙	a frequency missing from the T channel

The second error type indicates erroneous y-values (used in internal calculations):

Display:

Serial bus:

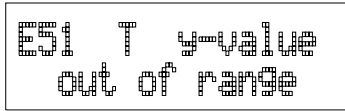

E51 T y-value out of range

- the temperature measurement cannot be completed. Check the temperature sensor and its solderings. Check the temperature measurement wires and their solderings on the component board (TP5,TP6,TP7 and TP8). If you cannot find any faults, send the transmitter to Vaisala for repair.

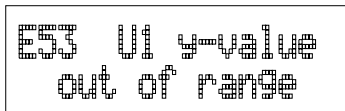

E53 U1 y-value out of range

- the humidity measurement cannot be completed. Check the HUMICAP sensor and humidity measurement wires and their solderings on the component board (TP9,TP10 and TP11/15). If you cannot find any faults, send the transmitter to Vaisala for repair.

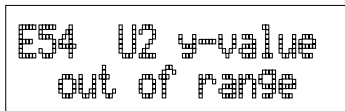

E54 U2 y-value out of range

- the measurement hybrid is probably damaged. Send the transmitter to Vaisala for repair.

The LEDs display these error types as follows:

⊗○○○	RH channel y-value out of range
○⊗○○	T channel y-value out of range

CALCULATION FORMULAS

The HMP230 series transmitters measure relative humidity and temperature. From these values dewpoint, mixing ratio, absolute humidity and enthalpy in normal pressure are calculated using the following equations

$$\text{dewpoint:} \quad T_d = \frac{T_n}{\frac{m}{\log\left(P_{ws} \cdot \frac{RH}{100 \cdot A}\right)} - 1}} \quad (1)$$

$$\text{mixing ratio:} \quad x = 621.98 \cdot RH \cdot \frac{P_{ws}}{(100 \cdot p - RH \cdot P_{ws})} \quad (2)$$

$$\text{absolute humidity:} \quad a = 216.68 \cdot RH \cdot \frac{P_{ws}}{100 \cdot (t + 273.2)} \quad (3)$$

$$\text{enthalpy:} \quad h = T \cdot (1.01 + 0.00189 \cdot x) + 2.5 \cdot x \quad (4)$$

where	T_d	=	dewpoint temperature (°C)
	P_{ws}	=	partial pressure of saturated water vapour (mbar)
	RH	=	relative humidity (%)
	x	=	mixing ratio (g/kg)
	p	=	atmospheric pressure (mbar)
	a	=	absolute humidity (g/m ³)
	T	=	temperature (°C)
	h	=	enthalpy (kJ/kg)

The partial pressure of water P_{ws} is calculated using equation:

$$\Theta = T - \sum_{i=0}^3 C_i T^i \quad (5)$$

where:	T	=	temperature in K
	C_i	=	coefficients
	C_0	=	0.4931358
	C_1	=	-0.46094296 * 10 ⁻²
	C_2	=	0.13746454 * 10 ⁻⁴
	C_3	=	-0.12743214 * 10 ⁻⁷

The vapour pressure (in Pascals) is calculated using equation:

$$\ln P_{ws} = \sum_{i=-1}^3 b_i \Theta^i + b_4 \ln \Theta \quad (6)$$

where: b_i = coefficients

$$b_{-1} = -0.58002206 * 10^4$$

$$b_0 = 0.13914993 * 10^1$$

$$b_1 = -0.48640239 * 10^{-1}$$

$$b_2 = 0.41764768 * 10^{-4}$$

$$b_3 = -0.14452093 * 10^{-7}$$

$$b_4 = 6.5459673$$

The parameters A , m , and T_n depend on temperature according to the following table:

t	A	m	T_n
0 ... 50 °C	6.1078	7.5000	237.3
50 ... 100 °C	5.9987	7.3313	229.1
100 ... 150 °C	5.8493	7.2756	225.0
150 ... 180 °C	6.2301	7.3033	230.0

When $T_d < 0$ and the transmitter is set to dewpoint calculation mode (FROST OFF), the parameters are as follows:

$$A = 6.119866 \quad m = 7.926104 \quad T_n = 250.4138$$

When $T_d < 0$ and the transmitter is set to frostpoint calculation mode (FROST ON), the parameters are as follows:

$$A = 6.1134 \quad m = 9.7911 \quad T_n = 273.47$$

ALARM OUTPUT UNIT

The alarm output unit consists of two alarm relays and two opto-isolated outputs (see Figure 1). The relay output 1 is available at screw terminal X1 and the relay output 2 at screw terminal X2. The opto-outputs are activated simultaneously with the corresponding relays and available at screw terminal X5.

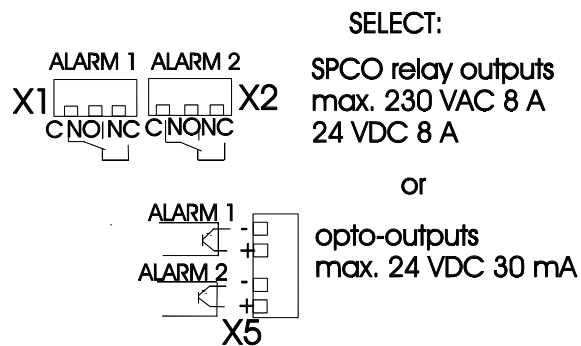

Figure 1 Relay and opto-outputs

When the relay is not activated, the C and NC outputs of the screw terminal are closed. When the relay is activated, these outputs are opened and the C and NO outputs are closed. If required, the relays can be activated by inserting a jumper to the test connector X4. By inserting the jumper to two pins on the left, relay 1 is activated and by inserting the jumper to two pins on the right, relay 2 is activated.

The alarm output unit is delivered with the alarm outputs in OFF mode (not in use). Therefore, the customer needs to set and take into use the desired outputs.

If the mains power is in use, only an authorized electrician may connect the alarm unit. A readily accessible disconnect device shall be incorporated in the fixed wiring (IEC 950).

For alarm output cabling, remove the plastic plug in the transmitter housing and replace it with the cable gland. Fasten the alarm unit to the bottom of the housing with four screws. Attach the grounding wire with the screw and washer to the grounding terminal on the right-hand side of the module if the mains power is in use. Attach the ribbon cable from X3 of the alarm unit to the X16 on the main board of the transmitter.

NOTE

NO jumper in connector X4 during normal operation.

When one alarm unit relay is on, the corresponding LED is lit.

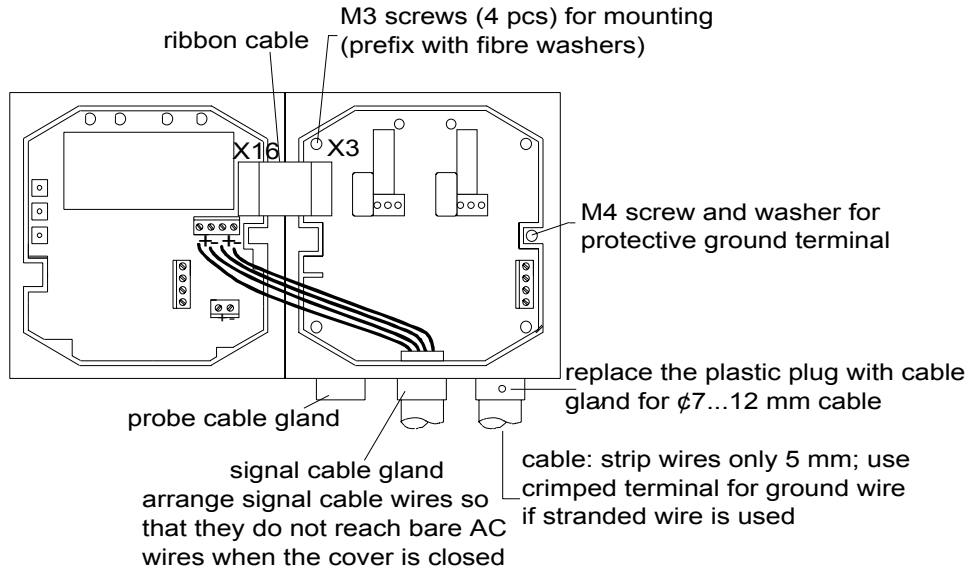

Prefix the fastening screws with fiber washers for mounting the unit to the box.

NOTE

The alarm unit cannot be used with the power supply unit HMP230PW.

NOTE

The alarm unit cannot be used with the HMP231 probe.

WARNING

Do not detach the alarm unit from the transmitter when the power is on.

WARNING

Do not connect the mains power to alarm unit without grounding the transmitter.

Setting and activating the outputs with menu commands

- Select MORE in the main menu and then ALARM; the following is displayed:

```
Ch1 Td HI ON
-20.00 5.00
```

- If the settings need to be changed, press CL:
 - the quantity starts blinking; it can be changed with arrow switches, and acknowledged with ENT.
 - the third parameter (in this example HI ON) starts blinking. This parameter determines whether the alarm output is in use or not, and when it is activated. The selection is acknowledged with ENT.

The options are the following:

- HI ON (the alarm is activated by exceeding the setpoint, the output is in use)
- LO ON (the alarm is activated if the value goes below the setpoint, the output is in use)
- HI OFF (the alarm is activated by exceeding the setpoint, the output is not in use)
- LO OFF (the alarm is activated if the value goes below the setpoint, the output is not in use)
- the setpoint starts blinking (in this example, -20.00); if you wish to change it, press CL and enter the new setpoint
- the hysteresis value starts blinking (in this example, 5.00); if you wish to change it, press CL and enter the new value

NOTE

The options HI OFF and LO OFF are used to deactivate the relay outputs e.g. for service purposes.

The settings of the channel 2 are changed in the same way.

Setting and activating the outputs using an RS line

```
ALARM <cr>
```

or

```
ALARM n ON <cr>
```

where n = channel number (1 or 2)

The currently valid settings of the alarm output unit can be checked with command ALARM:

```
>alarm<cr>
Ch1 RH LO OFF 0.00 0.00 %RH
Ch2 RH HI OFF 100.00 0.00 %RH
>
```

This is an example of the factory setting (both alarm outputs are in OFF mode, i.e. not in use). The settings can be changed with command ALARM:

```
>alarm 1 Td HI -20 5
Ch1 Td HI OFF -20.00 5.00 'C
Ch2 RH HI OFF 100.00 0.00 %RH
>
```

When giving this command, first enter the channel number i.e. the number of the alarm output you wish to use (1 or 2). Then select the quantity you wish to have on that channel:

- RH = relative humidity
- T = temperature
- Td = dewpoint temperature
- abs = absolute humidity
- mix = mixing ratio
- Tw = wet bulb temperature
- h = enthalpy.

The third parameter (HI/LO) determines whether the alarm is activated when the setpoint value is exceeded (HI) or not reached (LO). The fourth parameter is the actual setpoint value which activates the alarm. The last parameter is the hysteresis value; it indicates how much the measured value has to exceed or go below the setpoint before the alarm is deactivated. If the third parameter is HI, the alarm is deactivated when the measured value goes below the setpoint with the chosen hysteresis value; if the parameter is LO, the alarm is deactivated when the measured value exceeds the setpoint with the chosen hysteresis value.

When the alarm outputs have been set, you can activate the outputs with commands ALARM 1 ON (channel 1) or ALARM 2 ON (channel 2). Note that you can also activate the outputs when giving other parameters with command ALARM.

Examples of activating the outputs:

with command ALARM:

```
>alarm 1 Td HI -20 5
Ch1 Td HI ON -20.00 5.00 'C
Ch2 RH HI ON 100.00 0.00 %RH
>
```

with commands ALARM 1 ON and ALARM 2 ON:

```
>alarm 1 ON
Ch1 Td HI ON -20.00 5.00 'C
Ch2 T HI OFF 30.00 5.00 'C
>alarm 2 ON
Ch1 Td HI ON -20.00 5.00 'C
Ch2 T HI ON 30.00 5.00 'C
>
```

CONNECTORS

1.1	Connector options	141
1.2	Analogue outputs.....	141
1.3	Serial connections	142
1.4	Instructions for connecting and mounting the counter pieces.....	143

1.1 Connector options

The HMP230 series transmitters can be ordered with various connector configurations meaning that the sleeve or plug of the standard transmitter has been replaced with a connector. In the following, various options and signals.

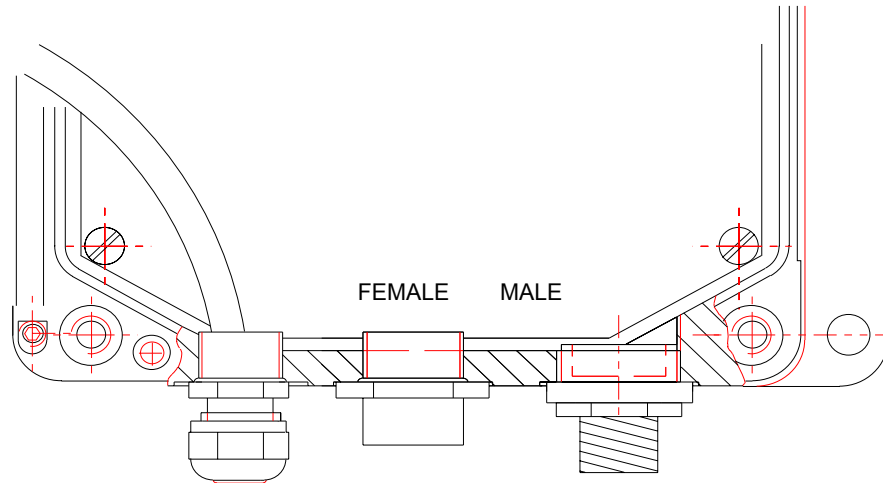

Figure 1 Connector location

1.2 Analogue outputs

Analogue outputs are selected when ordering the transmitter (order form has options for 0... 20 mA, 4... 20 mA, 0... 1V, 0... 5V and 0... 10V). They can be connected to a connector. If the transmitter is used the HMP230PW power supply module, only analogue outputs are connected to the connector. If the transmitter is operated with 24 VAC/VDC, also the power supply is connected to the same connector.

Part #	Connection 1	Connection 2
19372	24 VAC/VDC	HMP230PW
1	X1/24V+	X1/NC
2	X2/Ch1+	X2/Ch1+
3	X1/24V-	X2/Ch1-
4	X2/Ch2+	X2/Ch2+
5	X2/Ch2-	X2/Ch2-

The female connector (part no. 19372) is situated at the centre of the transmitter. The counter piece incorporating screw terminals (no. 19369) is delivered with each connector.

1.3 Serial connections

Also an RS232C serial bus can be connected to the connector; in this case, the connector is used mainly for maintenance and calibration purposes. Alternatively, a two wire RS 485 net can be built through the connector; in this case, also the power supply (24 VDC) is chained through transmitters.

RS232C connection

Part #	Connection
19371	
1	X6/Rx
2	X6/Tx
3	X6/GND-
4	X1/NC
5	X1/NC

The male connector (part n. 19371) is located on the right hand side of the transmitter. It is mounted with a sleeve socket Pg11/Pg9 (part no. 19813). The counter piece incorporating screw terminals (part no. 19370) is delivered with each connector.

RS485 single loop wiring

Part #	Connection	Part #	Connection
19372		19371	
1	X1/24V+	1	X1/24V+
2	X6/RxHi	2	X6/RxHi
3	X1/24V-	3	X1/24V-
4	X6RxLo	4	X6RxLo
5	X1/NC	5	X1/NC

The female connector (part no. 19372) is located at the centre of the transmitter. The male connector (part no. 19371) is located at the right hand side of the transmitter. It is mounted with with a sleeve socket Pg11/Pg9 (part no. 19813). Counter pieces (parts no. 19369 and 19370) are delivered with each connector. If the transmitter is removed for maintenance, the counter pieces can be connected to each other in order not to break the RS485 loop.

1.4 Instructions for connecting and mounting the counter pieces

The counter piece has to be grounded as shown in Figure 1.4 in order to maintain a complete EMC protection. The recommended cable is a shielded cable with an outer diameter of 4 - 6 mm, e.g. PFSK 6 x 0.22 mm.

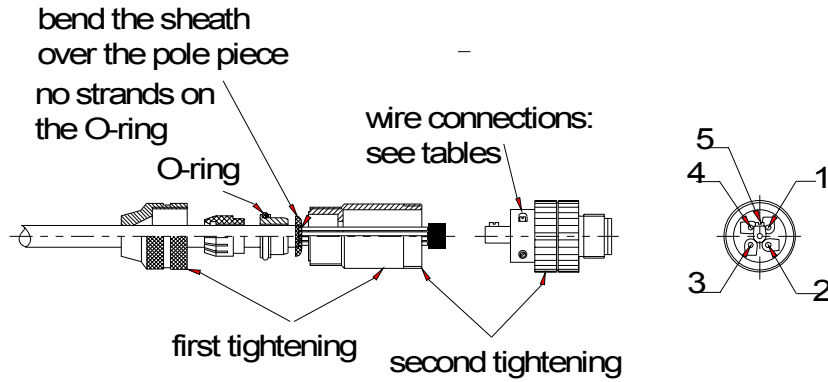

Figure 1.4 Connecting and grounding the connector

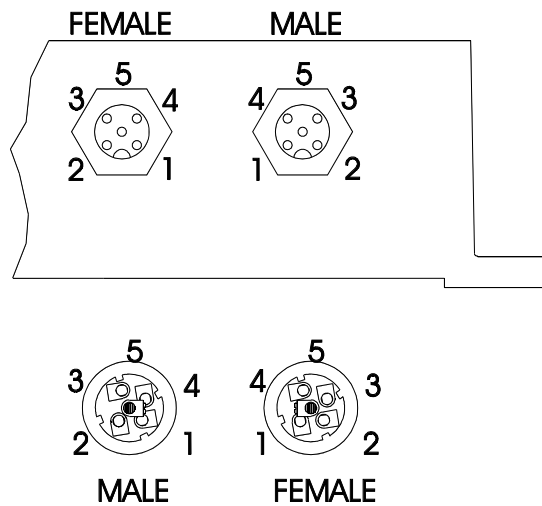

Figure 1.5 Counter piece numbering and their connection

RE-GAINING

1. GENERAL	145
2. TO BE NOTED IN RE-GAINING	146
3. LED COMMANDS	147
4. DISPLAY/KEYPAD COMMANDS	148
4.1. Re-gaining parameters	148
4.2. Starting re-gaining manually	149
5. SERIAL COMMANDS	150
REG Re-gaining settings	150
CR Re-gaining parameters	150
CRI Changing re-gaining parameters	151
FST Displaying re-gaining status	151
REGEN Starting re-gaining manually.....	152
6. TECHNICAL DATA	154

1. GENERAL

In some applications the sensor gain may decrease gradually due to an interference caused by some chemical present in the ambient (see Figure 1). The sensor polymer absorbs the interfering chemical; this reduces the polymer's ability to absorb water molecules and so decreases the sensor gain.

In re-gaining the interfering chemical is evaporated by heating the humidity sensor to a temperature level of approximately +160 °C. Automatic re-gaining (if active) is made repeatedly after time intervals defined by the user. Re-gaining can also be started manually using either LED, display/keypad or serial commands.

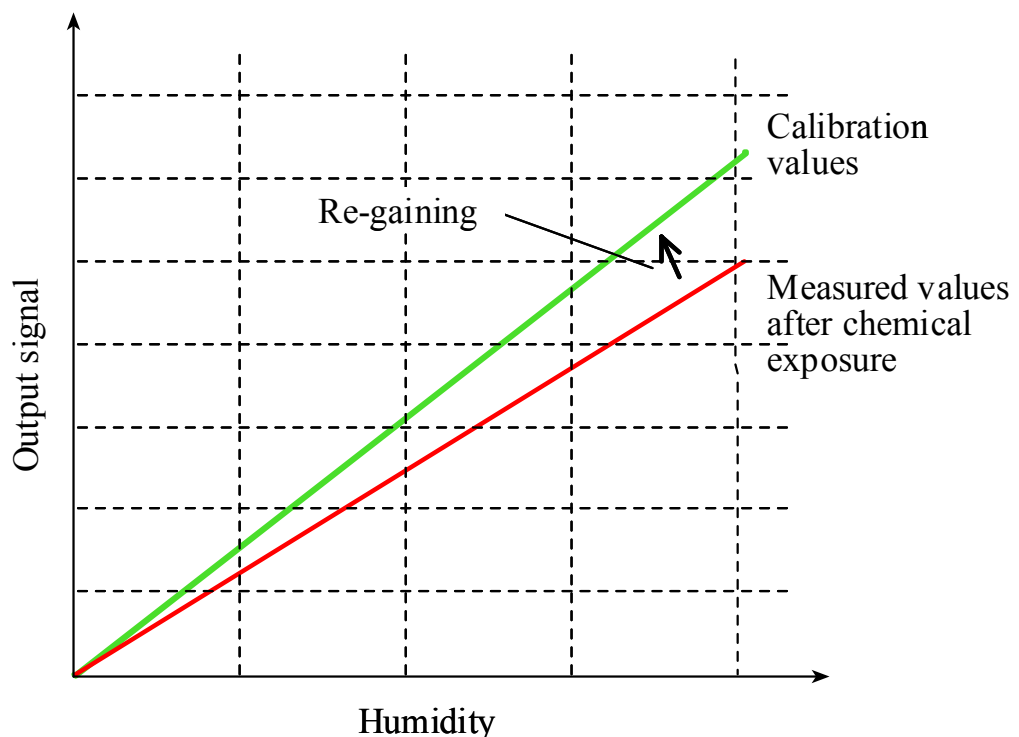

Fig. 1 Decrease of the sensor gain due to an interfering chemical and the effect of the re-gaining process.

The re-gainable sensor is a composite sensor in which the HUMICAP® and Pt 100 temperature sensors are glued together. Re-gaining option requires that the sensor is protected either with a PPS grid with stainless steel netting (part no. 16720HM) or with a stainless steel sintered filter (part no. 16452).

The power supply module (optional for the HMP230 series) cannot be used when the transmitter includes the re-gaining option.

2. TO BE NOTED IN RE-GAINING

Re-gaining cannot be started automatically or manually unless the security lock jumper is on. This is to prevent automatic re-gaining from starting during a sensor calibration (when the security lock jumper must be removed). Furthermore, re-gaining can be started only if the sensor temperature is below 100 °C. At higher temperatures the chemicals are evaporated from the sensor spontaneously, and the re-gaining is not needed.

NOTE

When the transmitter is humidity calibrated, the possible re-gaining must always be made before it, not after. Make sure that the temperature of the composite sensor has come down to normal temperature before starting a calibration.

Re-gaining can be automatic or it can be started manually. For automatic re-gaining five parameters are stored in the transmitter memory: the re-gaining interval, the duration of the sensor heating, the settling-cooling -time, the difference between the current sensor temperature and the ambient temperature measured before re-gaining and the k parameter (the power level the sensor is heated at). The parameter values can be changed by the user. The factory settings are

Interval	min	:	720
Duration	s	:	120
Temp diff		:	0.50
Settl time	s	:	240
k	%	:	95.00

The time interval between subsequent re-gainings starts at the end of the settling time.

During heating and settling periods both the analogue and serial outputs as well as the local display are locked to the values measured before re-gaining started. The outputs are released again when the sensor has cooled within the temperature difference setting, or when the settling period has ended whether sensor has cooled within the temperature difference or not.

The k parameter should not be changed from 95%. The recommended duration of heating is 120 s and it should not be changed either. The cooling time needed for the sensor to stabilize to the ambient temperature is strongly dependent on process conditions, especially on the speed of the air flow around the sensor head.

The settings for the temperature difference and the settling time should be determined carefully. If the settling time is too short the sensor is still warm when the outputs are released and the measured relative humidity value is too low as the temperature T value is too high. The factory setting (240 s) is

suitable in an ambient with a gas flow rate of 2 m/s or more around the sensor head. Furthermore, if the settling time is very long and the temperature difference small (close to zero) and the ambient temperature changes during re-gaining, the sensor may not reach the temperature difference within the settling time and the transmitter will remain inactive for a long period of time.

3. LED COMMANDS

Re-gaining can be started manually using the LED command ●●○○ (● = lit, ○ = dark). Use the up and down press switches (marked with arrows in the printed board) to find the command code and acknowledge it with the ENT switch. The re-gaining parameters stored in the transmitter memory are used. When re-gaining is over the LEDs are dark again.

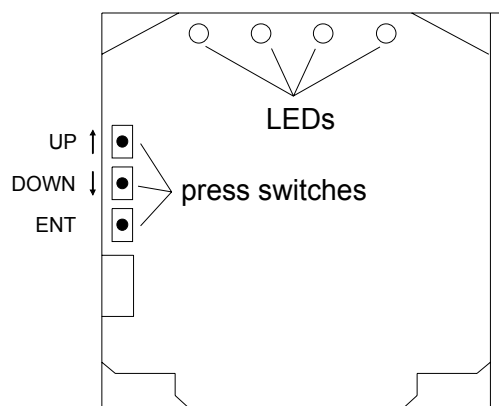

OPENED COVER OF THE HMP 230

Location of the press switches and LEDs

4. DISPLAY/KEYPAD COMMANDS

Press the CL key to enter the command mode. Select More from the first menu using the arrow keys and press ENT key. Select again More from the second menu and press ENT. The following menu is displayed:

```
Regen Echo Mtim  
Frost Test
```

Select Regen and press ENT.

```
Regen. settings  
Regeneration
```

To change or inspect the re-gaining parameter settings select Regen. settings and press ENT. To start re-gaining manually select Regeneration and press ENT.

4.1. Re-gaining parameters

The re-gaining parameters are displayed in a sequence of

- status of the automatic re-gaining
- re-gaining interval
- duration of heating
- temperature difference
- settling time
- k parameter

Each setting can be changed by entering a new parameter value using the arrow keys. **NOTE: disconnect the security lock jumper for changing these parameters!** After the parameter sequence the menu Regen.settings/Regeneration is displayed again. If you want to leave the parameters for the main menu, press CL once or several times. This leaves the rest of the parameters unchanged.

NOTE

To activate the new parameter settings immediately, the transmitter must be switched off/on. Otherwise the transmitter waits until the end of the old re-gaining interval and then starts re-gaining using the new parameters.

```

Regen          OFF
  
```

```

Regen          ON
  
```

Use arrow keys to change the status of the automatic re-gaining and press ENT.

```

Interval min :
              720
  
```

Acknowledge the current setting by pressing ENT. To change the interval press CL. Using arrow keys select the new time interval digit by digit and acknowledge each digit using ENT key. Using CL key you can correct the entry by deleting the digits one by one. When you have entered the whole time interval, press ENT for the second time.

```

Duration      s :
              120
  
```

```

Sett1 time   s :
              240
  
```

```

Temp diff    :
              0.50
  
```

```

k            % :
              95.00
  
```

With a similar manner acknowledge or change also the other re-gaining parameters.

When all the parameters have been changed or acknowledged, the menu Regen. settings/Regeneration is displayed again.

4.2. Starting re-gaining manually

To start re-gaining manually select Regeneration and press ENT. The following is displayed:

```

Regeneration . . .
any key to abort
  
```

When the heating is finished or it has been aborted, the settling period begins and the transmitter returns to the display mode outputting the measured or calculated values. However, during the settling time or until the temperature difference is small enough, the display is locked to the values measured before re-gaining was started. A new re-gaining cannot be started during the settling period.

5. SERIAL COMMANDS

REG Re-gaining settings

```
REG <cr>
REG nnn <cr>
```

nnn = ON or OFF

Command REG is used to check the re-gaining parameter settings and to activate or inactivate the automatic re-gaining.

Examples: checking the current settings

```
>reg
REG OFF                                automatic re-gaining is inactive
Interval min : 720
Duration s : 120
Temp diff : 0.50
Settl time s : 240
k % : 95.00
>
```

activating the automatic re-gaining

```
>reg on
REG ON
>
```

deactivating the automatic re-gaining

```
>reg off
REG OFF
>
```

CR Re-gaining parameters

```
CR <cr>
```

Command CR can be used to check the values of re-gaining parameters.

Example:

```
>cr
Interval min : 720
Duration s : 120
Temp diff : 0.50
Settl time s : 240
k % : 95.00
>
```

CRI Changing re-gaining parameters

Disconnect the security lock jumper!

CRI <cr>

With command CRI the values of the re-gaining parameters can be changed.

Example: changing the re-gaining interval to 480 min and the settling time after sensor heating to 360 s

```
>cri
Interval min :      720 ? 480
Duration s :      120 ?
Temp diff :      0.50 ?
Settl time s :      240 ? 360
k % :      95.00 ?
>
```

NOTE

To activate new parameter settings immediately, command RESET must be given. Otherwise the transmitter waits until the end of the old re-gaining interval and then starts re-gaining using the new parameters.

FST Displaying re-gaining status

FST nnn <cr>

nnn = ON or OFF

With FST ON the status of the re-gaining is output at the beginning of the output line.

Example: activating status display

```
>fst on
Form. status : ON
>r
N 0 RH= 20.8 %RH T= 25.6 'C N = re-gaining off
N 0 RH= 20.7 %RH T= 25.6 'C
N 0 RH= 20.7 %RH T= 25.6 'C
N 0 RH= 20.8 %RH T= 25.6 'C
H 163 RH= 20.8 %RH T= 25.6 'C H = heating on, 163
H 163 RH= 20.8 %RH T= 25.6 'C describes the heating
H 163 RH= 20.8 %RH T= 25.6 'C power
H 163 RH= 20.8 %RH T= 25.6 'C
S 163 RH= 20.8 %RH T= 25.6 'C S = settling period on
S 163 RH= 20.8 %RH T= 25.6 'C
S 163 RH= 20.8 %RH T= 25.6 'C
S 163 RH= 20.8 %RH T= 25.6 'C
N 163 RH= 20.8 %RH T= 25.6 'C
N 163 RH= 15.0 %RH T= 31.5 'C
N 163 RH= 16.7 %RH T= 30.0 'C
N 163 RH= 17.4 %RH T= 29.1 'C
H 160 RH= 17.7 %RH T= 28.6 'C H = new heating (new
H 160 RH= 17.7 %RH T= 28.6 'C power)
```

deactivating status display

```
>fst off
Form. status : OFF
>r
RH= 20.1 %RH T= 26.4 'C
RH= 20.2 %RH T= 26.4 'C
RH= 20.1 %RH T= 26.4 'C
RH= 20.2 %RH T= 26.4 'C
```

REGEN Starting re-gaining manually

REGEN <cr>

Re-gaining can also be started manually with command REGEN. The current re-gaining parameters (duration and settling times stored with command CRI) are used.

Example: starting re-gaining

```
>regen
Regeneration started, press any key to abort
>
```

The prompt '>' appears when the heating period is over. However, the transmitter outputs are locked to values measured before re-gaining until the settling time is over.

Example:

```
>regen
Regeneration started, press any key to abort
>r
S 162 RH= 20.0 %RH T= 26.5 'C      heating is finished,
S 162 RH= 20.0 %RH T= 26.5 'C      settling time is on and
S 162 RH= 20.0 %RH T= 26.5 'C      outputs are locked
...
N 162 RH= 18.4 %RH T= 27.7 'C      settling time is over and
N 162 RH= 18.5 %RH T= 27.6 'C      outputs are released
N 162 RH= 18.8 %RH T= 27.5 'C
```

Re-gaining cannot be started if automatic re-gaining (heating/cooling) is on at that moment, the temperature of the sensor exceeds 100 °C or the security lock jumper is off. In these cases the 'Regeneration started...' text is not output by the transmitter but the prompt '>' appears immediately.

Example:

```
>regen
>r
H 162 RH= 19.7 %RH T= 26.4 'C      forced re-gaining failed
H 162 RH= 19.7 %RH T= 26.4 'C      as automatic re-gaining
H 162 RH= 19.7 %RH T= 26.4 'C      (heating) is going on
```

6. TECHNICAL DATA

Power consumption during re-gaining
(without alarm output unit) 170 mA maximum (24 VDC)

NOTE

The optional power supply module cannot be used in a transmitter which includes the re-gaining option.

Sensor	RH & T composite sensor (part no. 17550HM)
Sensor protection	PPS grid with stainless steel netting (part no. 16720HM) stainless steel sintered filter (part no. 16452)

For other properties of the sensor heads see Chapter 8. Technical data in the Operating manual.

PRESSURE UNIT CONVERSION CHART

Multiplication factors

NOTE: conversions from mmHg and inHg are defined at 0°C and for mmH₂O and inH₂O at 4°C.

FROM:	TO: hPa/mbar
PaN/m²	0.01
mmHg torr	1.333224
inHg	33.86388
mmH₂O	0.09806650
inH₂O	2.490889
atm	1013.25
at	980.665
bar	1000
psi	68.94757

psia = psi absolute

Example: 29.9213 inHg = 29.9213 x 33.86388 = 1013.25 hPa/mbar

APPENDIX 11

WIRING DIAGRAM

Note ! The cable shield has to be connected to the cable bushing for full EMC protection.

In automation system the galvanically isolated inputs are recommended for current signals

To control system

(To control system)

Supply voltage 24 VDC
max. HMP230 series 100 mA
(with re-gaining 170 mA)
HMP260 series 120 mA

(HMP230: for 24 VAC,
see the Operating Manual)

Main board HMP230 and HMP260

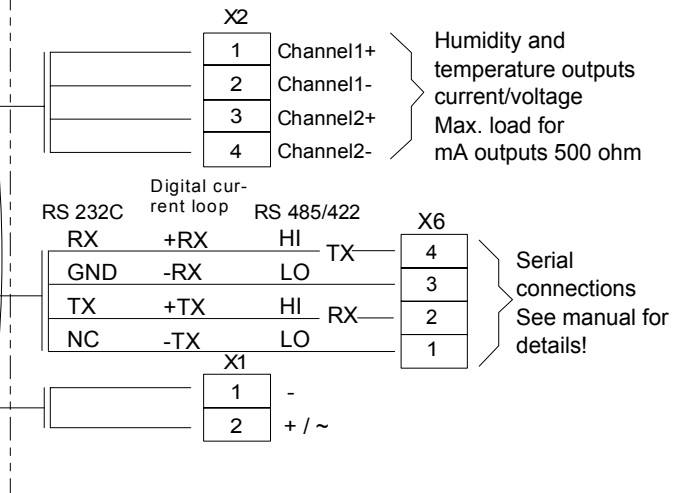

Output voltage 24 VDC
Supply voltage 115/230 VAC

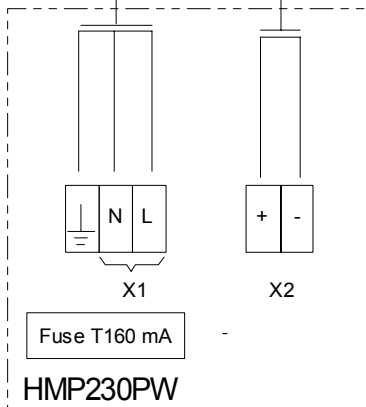

Location of main board terminals

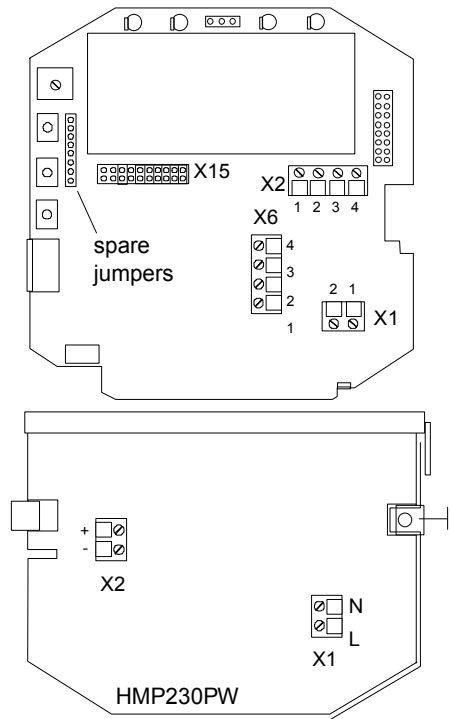

Jumper selections in connector X15

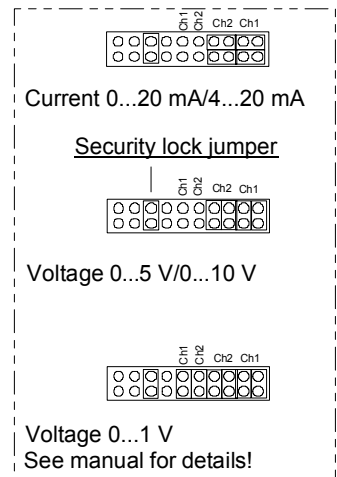

Note.
the output settings must be also programmed

Note. HMP230PW module cannot be used with HMP260 transmitters.

Warranty

Vaisala hereby represents and warrants all Products manufactured by Vaisala and sold hereunder to be free from defects in workmanship or material during a period of twelve (12) months from the date of delivery save for products for which a special warranty is given. If any Product proves however to be defective in workmanship or material within the period herein provided Vaisala undertakes to the exclusion of any other remedy to repair or at its own option replace the defective Product or part thereof free of charge and otherwise on the same conditions as for the original Product or part without extension to original warranty time. Defective parts replaced in accordance with this clause shall be placed at the disposal of Vaisala.

Vaisala also warrants the quality of all repair and service works performed by its employees to products sold by it. In case the repair or service works should appear inadequate or faulty and should this cause malfunction or nonfunction of the product to which the service was performed Vaisala shall at its free option either repair or have repaired or replace the product in question. The working hours used by employees of Vaisala for such repair or replacement shall be free of charge to the client. This service warranty shall be valid for a period of six (6) months from the date the service measures were completed.

This warranty is however subject to following conditions:

- a) A substantiated written claim as to any alleged defects shall have been received by Vaisala within thirty (30) days after the defect or fault became known or occurred, and
- b) The allegedly defective Product or part shall, should Vaisala so require, be sent to the works of Vaisala or to such other place as Vaisala may indicate in writing, freight and insurance prepaid and properly packed and labelled, unless Vaisala agrees to inspect and repair the Product or replace it on site.

This warranty does not however apply when the defect has been caused through

- a) normal wear and tear or accident;
- b) misuse or other unsuitable or unauthorized use of the Product or negligence or error in storing, maintaining or in handling the Product or any equipment thereof;
- c) wrong installation or assembly or failure to service the Product or otherwise follow Vaisala's service instructions including any repairs or installation or assembly or service made by unauthorized personnel not approved by Vaisala or replacements with parts not manufactured or supplied by Vaisala;
- d) modifications or changes of the Product as well as any adding to it without Vaisala's prior authorization;
- e) other factors depending on the Customer or a third party.

Notwithstanding the aforesaid Vaisala's liability under this clause shall not apply to any defects arising out of materials, designs or instructions provided by the Customer.

This warranty is expressly in lieu of and excludes all other conditions, warranties and liabilities, express or implied, whether under law, statute or otherwise, including without limitation any implied warranties of merchantability or fitness for a particular purpose and all other obligations and liabilities of Vaisala or its representatives with respect to any defect or deficiency applicable to or resulting directly or indirectly from the Products supplied hereunder, which obligations and liabilities are hereby expressly cancelled and waived. Vaisala's liability shall under no circumstances exceed the invoice price of any Product for which a warranty claim is made, nor shall Vaisala in any circumstances be liable for lost profits or other consequential loss whether direct or indirect or for special damages.